

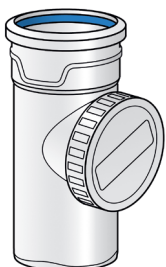

ASP510 PHONEX AS-PLUS Putzstück



Symbolgrafik

Produktbeschreibung:

PP - Mineralverstärktes hochschalldämmendes Formstück, mit angeformter Steckmuffe, patentierten Lippen-
dichtring mit integriertem Gleitmittel und Hexagon-Anfasung zur Reduzierung der Einsteckkräfte

Produkteigenschaften:

Anschluss 1	Rohrende	Anschluss 2	Einsteck
--------------------	----------	--------------------	----------

Erweiterte Produkteigenschaften:

Art.-Nr.	Bezeichnung	Gewicht	VPE1	VPE2	Mengeneinheit
14810HHO	50	0,25 KGM	6	288	STK
14810JJO	75	0,58 KGM	8	192	STK
14810KKO	90	0,65 KGM	4	192	STK
14810LLO	110	1,06 KGM	4	96	STK
14810MMO	125	1,6 KGM	2	48	STK
14810PPD	160	1,8 KGM	2	48	STK





ASP510 PHONEX AS-PLUS Putzstück

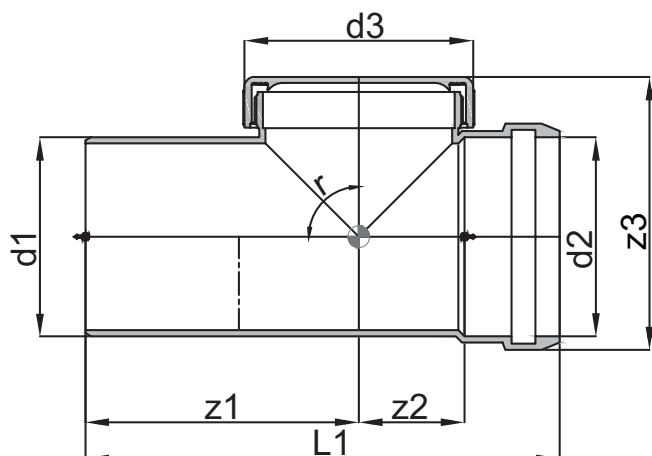

Art.-Nr.	Bezeichnung	d1	d2	d3	L1	z1	z2	z3
14810HHO	50	50	50	65	164	82	37	84
14810JJ0	75	75	75	93	200	97	53	111
14810KK0	90	90	90	111	228	114	62	131
14810LLO	110	110	110	130	258	129	72	156
14810MM0	125	125	125	130	259	127	71	174
14810PP0	160	160	160	130	271	135	68	213

