

# KELOX

## KMU410 KELOX-ULTRAX Spojka 20/18

71100DC0

### aplikační oblasti

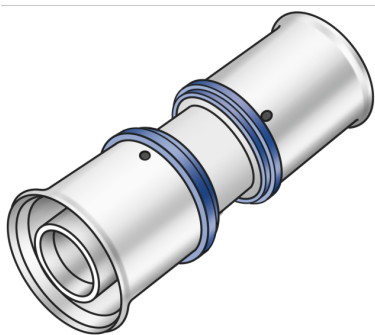

Lisovaná spojka rovnoměrná nebo redukováná, mosaz bez porů metalizovaná, včetně opěrné objímky s O-kroužky a lisovanými objímkami z oceli, případně nerezové oceli, "neslisované netěsné"

### certifikace



KE KELIT GmbH

A 4020 Linz, Ignaz-Mayer-Straße 17, Austria, Europe

PHONE +43 (0) 50 779 E-MAIL [office@kekelit.com](mailto:office@kekelit.com)

[www.kekelit.com](http://www.kekelit.com)

# specifikace

## informace o výrobku

port 1	Pressmuffe
port 2	Pressmuffe
execution	1-teilig
design	gerade
press contour	U

## technické charakteristiky

maximum working pressure at 20 ° C	10 bar
------------------------------------	--------

## produktové informace

VPE1	10 SA1
VPE2	160 KT1
weight	0,061 KGM
text	KELOX-ULTRAX Spojka
INTRNR	74122000
main material group	KELOX
material group	KELOX-ULTRAX Kovové tvarovky
code	KMU410

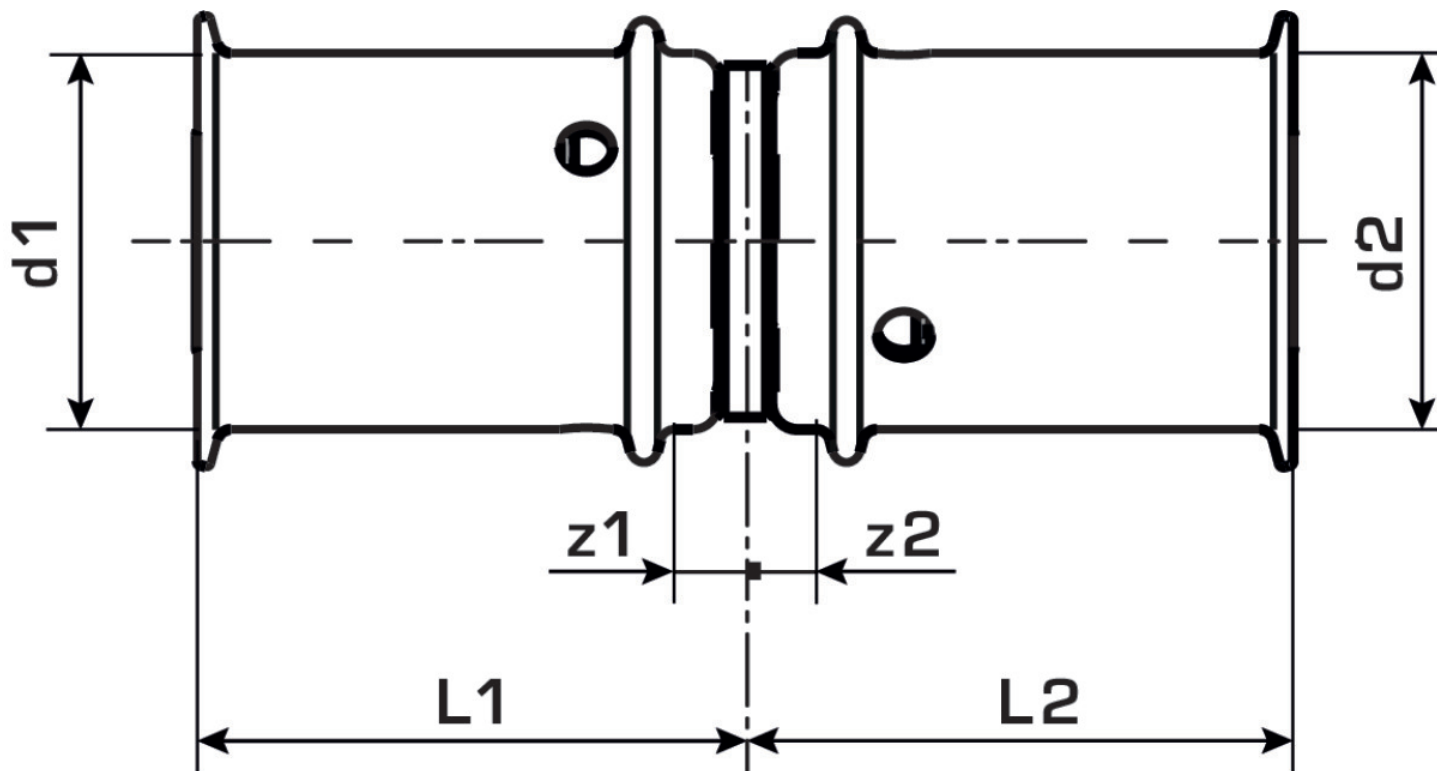

Art. No	label	d1 mm	d2 mm	L1 mm	L2 mm	z1 mm	z2 mm
71100DC0	20/18	20	18	27	25	1.5	1