

KELOX

KMU410 KELOX-ULTRAX Spojka 63/50

71100IH0

aplikační oblasti

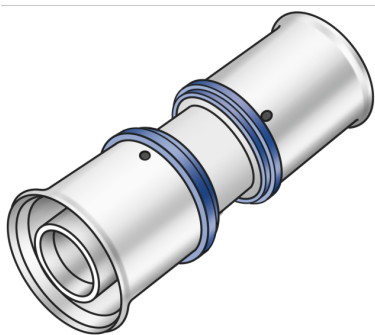

Lisovaná spojka rovnoměrná nebo redukováná, mosaz bez pórov metalizovaná, včetně opěrné objímky s O-kroužky a lisovanými objímkami z oceli, případně nerezové oceli, "neslisované netěsné"

certifikace



specifikace

informace o výrobku

port 1	Pressmuffe
port 2	Pressmuffe
execution	1-teilig
design	gerade
press contour	U

technické charakteristiky

maximum working pressure at 20 ° C	10 bar
------------------------------------	--------

produktové informace

VPE1	1 SA1
VPE2	8 KT1
weight	0,681 KGM
text	KELOX-ULTRAX Spojka
INTRNR	74122000
main material group	KELOX
material group	KELOX-ULTRAX Kovové tvarovky
code	KMU410

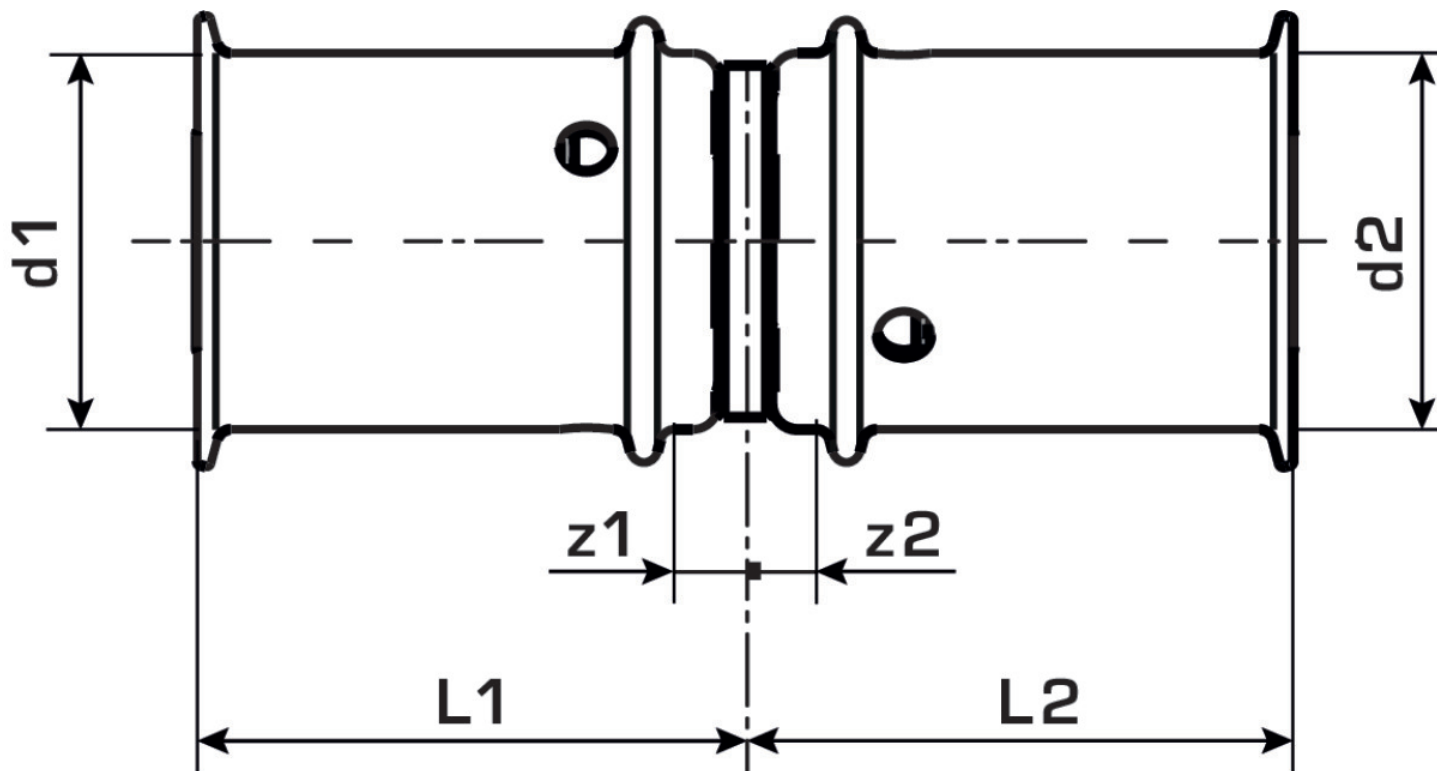

Art. No	label	d1 mm	d2 mm	L1 mm	L2 mm	z1 mm	z2 mm
71100IH0	63/50	63	50	84	55	21	15