

KELOX

KMU467 KELOX-ULTRAX Koleno 90° s vnitřním závitem 16x1/2"

71216B02

aplikační oblasti

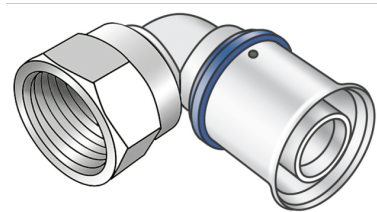

Lisované p?echodové koleno s vnitřním závitem, mosaz bez pór? metalizovaná, v?etné op?rné objímky s O-kroužky a lisovanými objímkami z oceli p?íp. ušlechtilé oceli, "nezalisované net?sné" nešroubujte závitové trubky a tvarovky z temperované slitiny!

certifikace



specifikace

informace o výrobku

port 1	Pressmuffe
execution	1-teilig
design	Winkel
angle	90 °
press contour	U

technické charakteristiky

maximum working pressure at 20 ° C	10 bar
------------------------------------	--------

produktové informace

VPE1	10 SA1
VPE2	180 KT1
weight	0,072 KGM
text	KELOX-ULTRAX Koleno 90° s vnitřním závitem
INTRNR	74122000
main material group	KELOX
material group	KELOX-ULTRAX Kovové tvarovky
code	KMU467

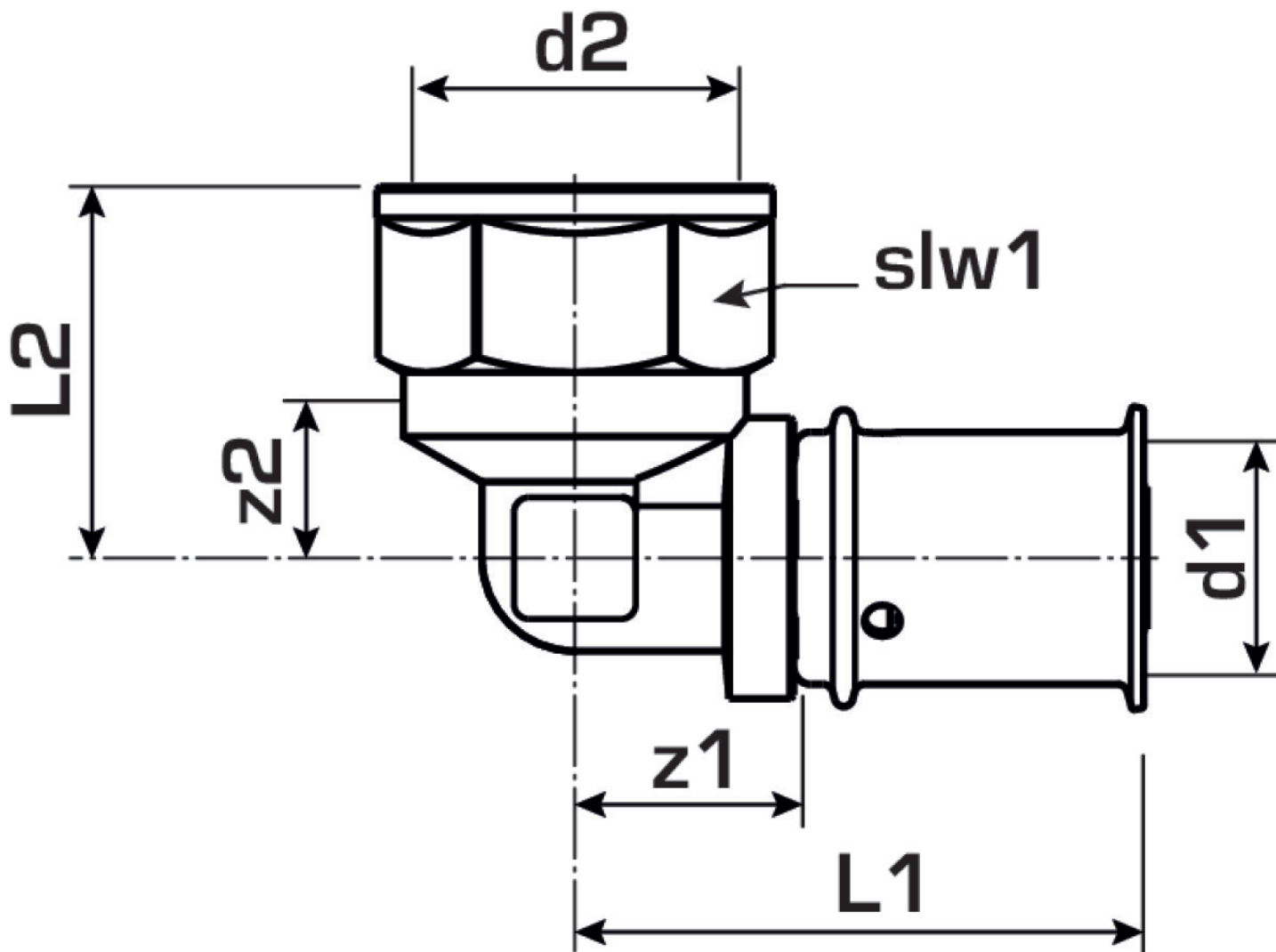

Art. No	label	d2	d1 mm	L1 mm	z1 mm	z2 mm	slw2 mm
71216B02	16x1/2"	1/2 Zoll (15)	16	38.5	16	29	24