

KELOX

KMU467 KELOX-ULTRAX Koleno 90° s vnitřním závitem 32x1"

71216F05

aplikační oblasti

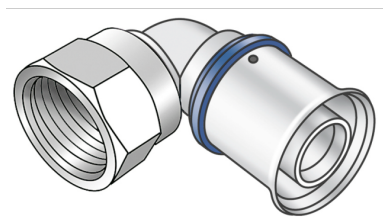

Lisované p?echodové koleno s vnitřním závitem, mosaz bez pór? metalizovaná, v?etné op?rné objímky s O-kroužky a lisovanými objímkami z oceli p?íp. ušlechtilé oceli, "nezalisované net?sné" nešroubujte závitové trubky a tvarovky z temperované slitiny!

certifikace



KE KELIT GmbH

A 4020 Linz, Ignaz-Mayer-Straße 17, Austria, Europe

PHONE +43 (0) 50 779 E-MAIL office@kekelit.com

www.kekelit.com

specifikace

informace o výrobku

port 1	Pressmuffe
execution	1-teilig
design	Winkel
angle	90 °
press contour	U

technické charakteristiky

maximum working pressure at 20 ° C	10 bar
------------------------------------	--------

produktové informace

VPE1	6 SA1
VPE2	54 KT1
weight	0,26 KGM
text	KELOX-ULTRAX Koleno 90° s vnitřním závitem
INTRNR	74122000
main material group	KELOX
material group	KELOX-ULTRAX Kovové tvarovky
code	KMU467

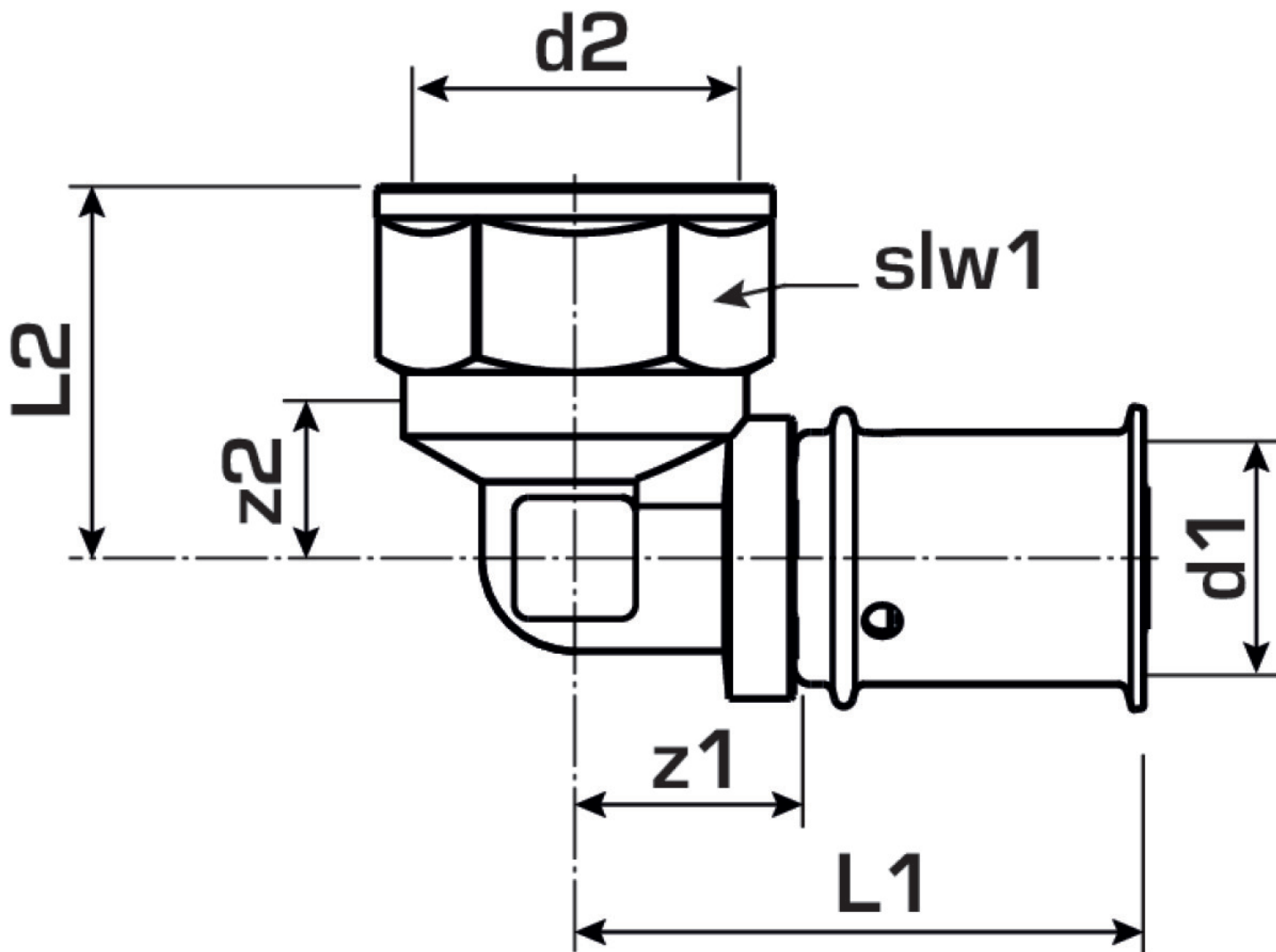

Art. No	label	d2	d1 mm	L1 mm	z1 mm	z2 mm	slw2 mm
71216F05	32x1"	1 1/4 Zoll (32)	32	58	24	39	38