

KELOX

KMP410 KELOX-PROTEC Spojka 20/16

73100DB0

aplikační oblasti

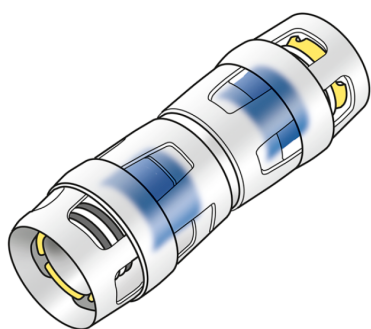

Zasouvací spojka rovnoměrná nebo redukovaná, z mosazi bez porů metalizovaná, včetně opěrné objímky, s O-kroužky, vytahovacími bariérami a ochranným kroužkem jako zasouvací pojistkou

certifikace



specifikace

informace o výrobku

port 1	Einsteck
port 2	Einsteck
execution	sonstige
design	gerade

produktové informace

VPE1	10 SA1
VPE2	140 KT1
weight	0,055 KGM
text	KELOX-PROTEC Spojka
INTRNR	74122000
main material group	KELOX
material group	KELOX-PROtec Nasúvacie tvarovky
code	KMP410

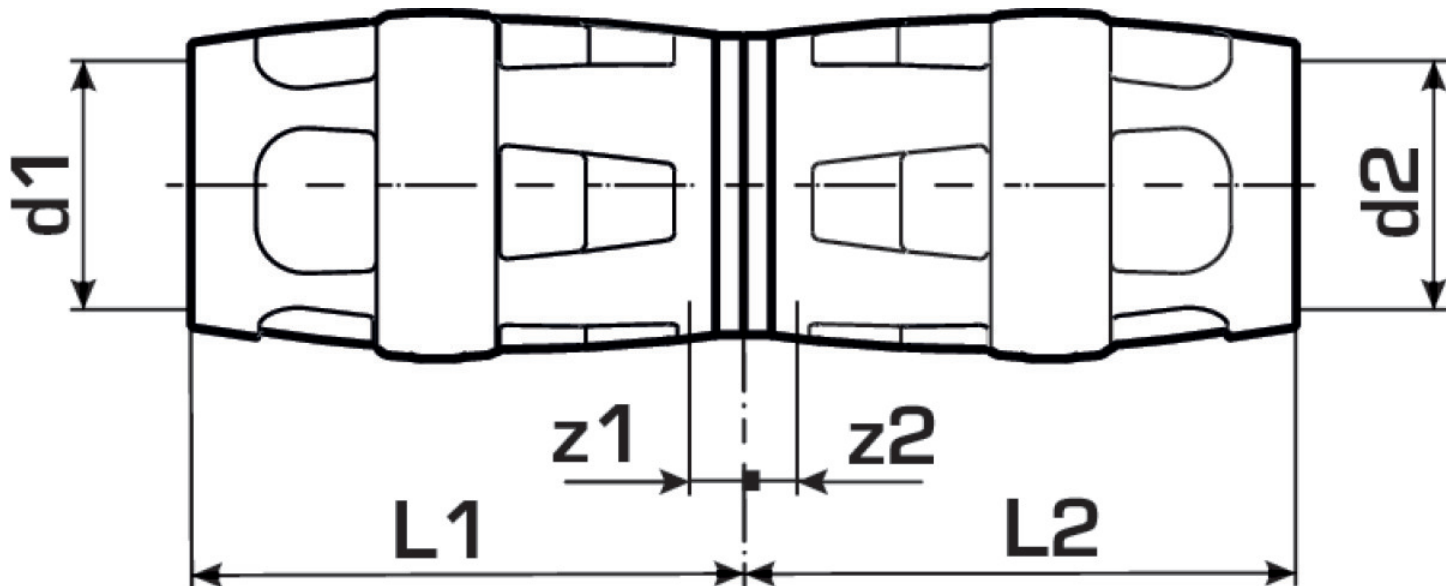

Art. No	label	d1 mm	d2 mm	L1 mm	L2 mm	z1 mm	z2 mm
73100DB0	20/16	20	16	36	36	3	3