

KELOX

KMU451 KELOX-ULTRAX Holländer mit AG 40x5/4"

71241G06

aplika?ní oblasti

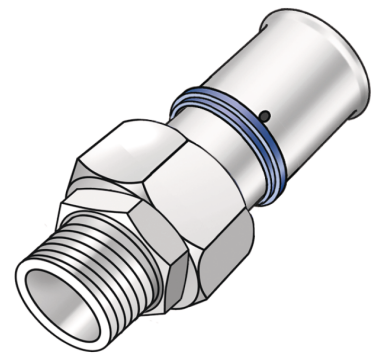

ULTRAX Press-Holländer mit AG aus Edelstahl, Gewinde gemäß ÖNORM EN 10226, zum Anschluss an Armaturen, aus Messing porenfrei metallisiert, inkl. Stützhülsen mit O-Ringen und Edelstahl-Presshülsen, "unverpresst undicht", flach dichtend inkl. Dichtung

certifikace



KE KELIT GmbH

A 4020 Linz, Ignaz-Mayer-Straße 17, Austria, Europe

PHONE +43 (0) 50 779 E-MAIL office@kekelit.com

www.kekelit.com

specifikace

informace o výrobku

port 1	Pressmuffe
port 2	Außengewinde konisch (NPT)
execution	2-teilig
design	gerade
press contour	U

technické charakteristiky

maximum working pressure at 20 ° C	10 bar
------------------------------------	--------

produktové informace

VPE1	5,00 SA1
weight	0,518 KGM
text	KELOX-ULTRAX Holländer mit AG
INTRNR	74122000
main material group	KELOX
material group	KELOX-ULTRAX Metallformstücke
code	KMU451

