

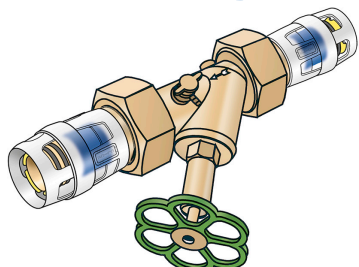

KMP452X KELOX-PROTEC CLIX Schrägsitzventil



Symbolgrafik

Produktbeschreibung:

Schrägsitzventil, mit PROTEC CLIX Steck-Verschraubungen KMP455 Oberteil „totraumfrei“, flach dichtend inkl. Dichtung und Entleerung



kiwa



Produkteigenschaften:

ÖVGW	W 1.235	DVGW	DW-8501CM0535
SVGW	1209-6082	Material	Messing
Max. Mediumtemperatur (Dauerbetrieb)	70 °C	Min. Mediumtemperatur (Dauerbetrieb)	-20 °C

Erweiterte Produkteigenschaften:

Art.-Nr.	Bezeichnung	Gewicht	VPE1	VPE2	Mengeneinheit
730233BB0	16-DN15	0,594 KGM	1	14	STK
730233DD0	20-DN15	0,616 KGM	1	10	STK
730233EE0	25-DN20	1,104 KGM	1	8	STK
730233FF0	32-DN25	1,710 KGM	1	6	STK





KMP452X KELOX-PROTEC CLIX Schrägsitzventil

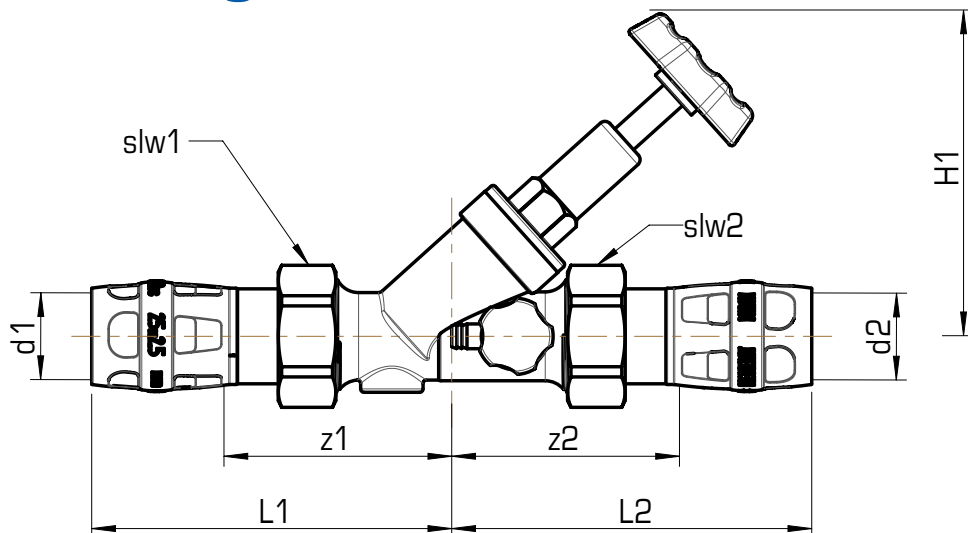

Art.-Nr.	Bezeichnung	d1/d2 mm	H1 mm	slw1	slw2	L1 mm	z1 mm	L2 mm	z2 mm
730233BB0	16-DN15	16	92	30	30	93	60	93	60
730233DD0	20-DN15	20	92	30	30	93	60	93	60
730233EE0	25-DN20	25	106	38	38	106	67	106	67
730233FF0	32-DN25	32	119	47	47	117	78	117	78

