

KELOX

KMU457 KELOX-ULTRAX adapter female 63x2"

71206I09

Areas of application

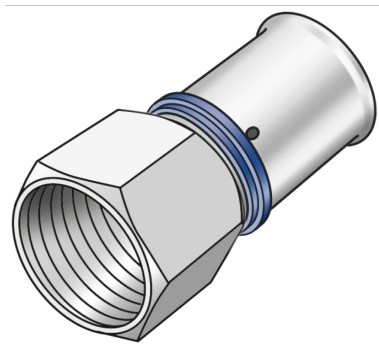

Press adapter with female thread, made of non-porous metallised brass; including support sleeves with O-rings and stainless steel d16-50mm press-fit sleeves; "leak before pressed"
DO NOT screw in any threaded pipes and cast iron fittings!

Approvals:



Specifications

Article information

port 1	Pressing socket
port 2	Female thread cylindrical BSPT-Rp (ISO 7-1)
execution	1-part
design	Straight
press contour	U

Technical properties

maximum working pressure at 20 ° C	10 bar
------------------------------------	--------

Product information

VPE1	1,00 SA1
VPE2	15,00 KT1
weight	0,784 KGM
text	KELOX-ULTRAX adapter female
INTRNR	74122000
main material group	KELOX
material group	KELOX-ULTRAX metal fittings
code	KMU457



Art. No	label	d2 Inches	d1 mm	L1 mm	L2 mm	z1 mm	z2	slw1	slw2 mm
71206109	63x2"	2"	63	70	25	29,5	2	74	70