

# KELOX

## KMU480L KELOX-ULTRAX wall bracket fitting 90° with 20mm female thread 20x1/2"

71251D02

### Areas of application

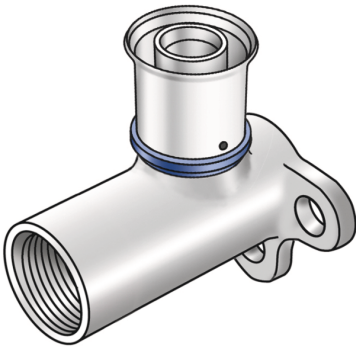

Press-fit wall bracket fitting elbow with female thread, extended by 20mm, made from non-porous metallised brass; including support sleeves with O-rings and stainless steel press-fit sleeves, "leak before pressed"

Overall height:

1/2" - 66.5mm

DO NOT screw in threaded pipes and cast iron fittings!

## Approvals:



# Specifications

## Article information

port 1	Pressmuffe
design	Durchgängig rechtwinklig
press contour	U

## Technical properties

maximum working pressure at 20 ° C	10 bar
------------------------------------	--------

## Product information

VPE1	10,00 SA1
VPE2	60,00 KT1
weight	0,173 KGM
text	KELOX-ULTRAX wall bracket fitting 90° with 20mm female thread
INTRNR	74122000
main material group	KELOX
material group	KELOX-ULTRAX metal fittings
code	KMU480L

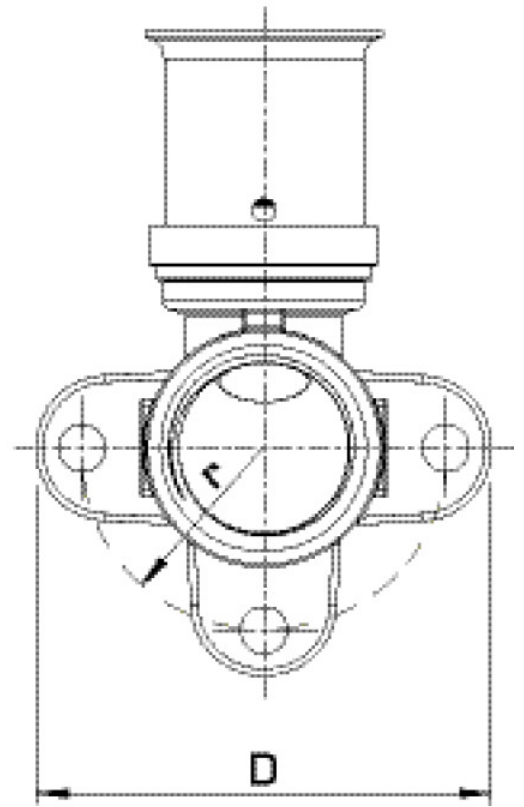
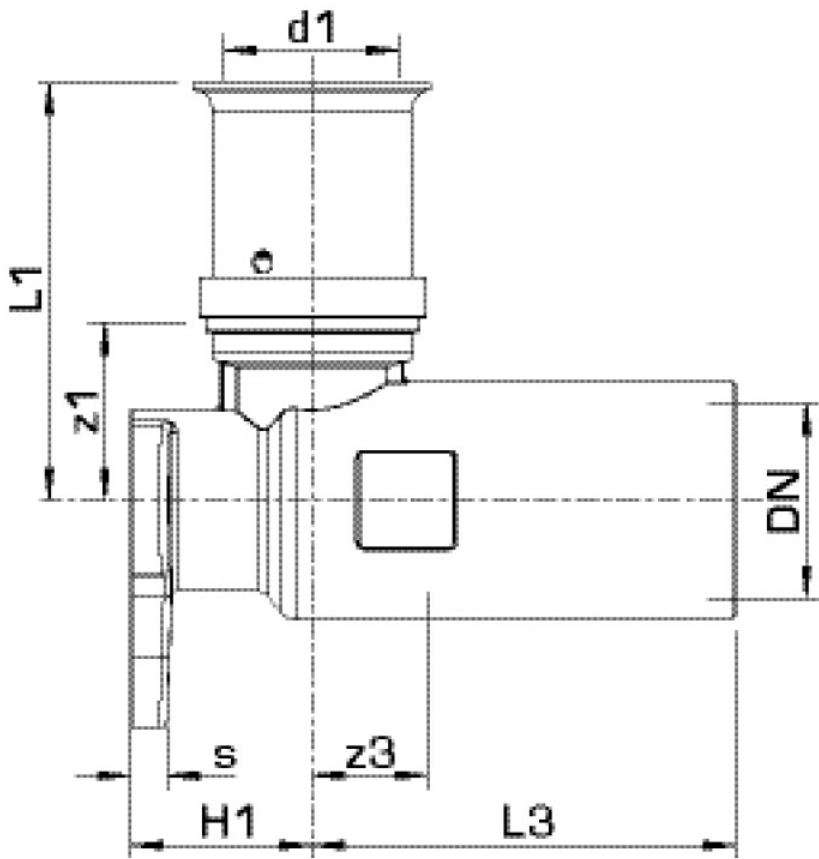

Art. No	label	d1 mm	L1 mm	L3 mm	z1 mm	z3 mm
71251D02	20x1/2"	20	46	46,5	20	12