

KELOX

KWW485 ?KELOX-WINDOW-W connection set 16x1/2" 8-10cm

72462B02

Areas of application

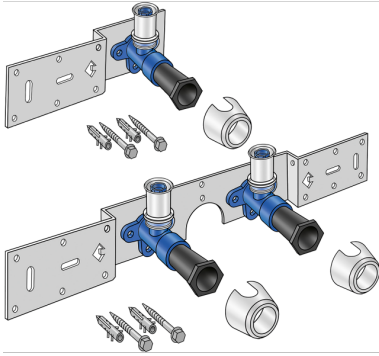

?With zeta value-optimised KWW480 90° elbow wall bracket fitting, sound-insulated, plug, metal bracket, anchors and fasteners, "leak before pressed" audible leakage signal at air-pressure testing
DO NOT screw in threaded pipes and cast iron fittings!
DO NOT use liquid sealants!

Approvals:



Specifications

Product information		
VPE1		1,00 KT1
VPE2		15,00 KT2
weight		0,799 KGM
text		?KELOX-WINDOW-W connection set
INTRNR		39174000
main material group		KELOX
code		KWW485

Art. No	label	d1 mm
72462B02	16x1/2" 8-10cm	16