

# STEEL FIX C-STAHl

## CP453 C-Steel press-ball valve 15

54728BB0

### Areas of application



Press-fit ball valve with full bore, ball and basic body with full flow, made of carbon steel coated with a zinc layer, incl. EPDM sealing components, "leak before pressed"

Press contour: M

Operating temperature: - 35°C - tmax 135°C

# Specifications

## Article information

port 1	Pressmuffe
port 2	Pressmuffe
execution	gerade

## Product information

VPE1	1 SA1
VPE2	25 KT1
weight	0,17 KGM
text	C-Steel press-ball valve
INTRNR	84818081
main material group	STEELFIX
material group	C-STAHL pressfittings
code	CP453

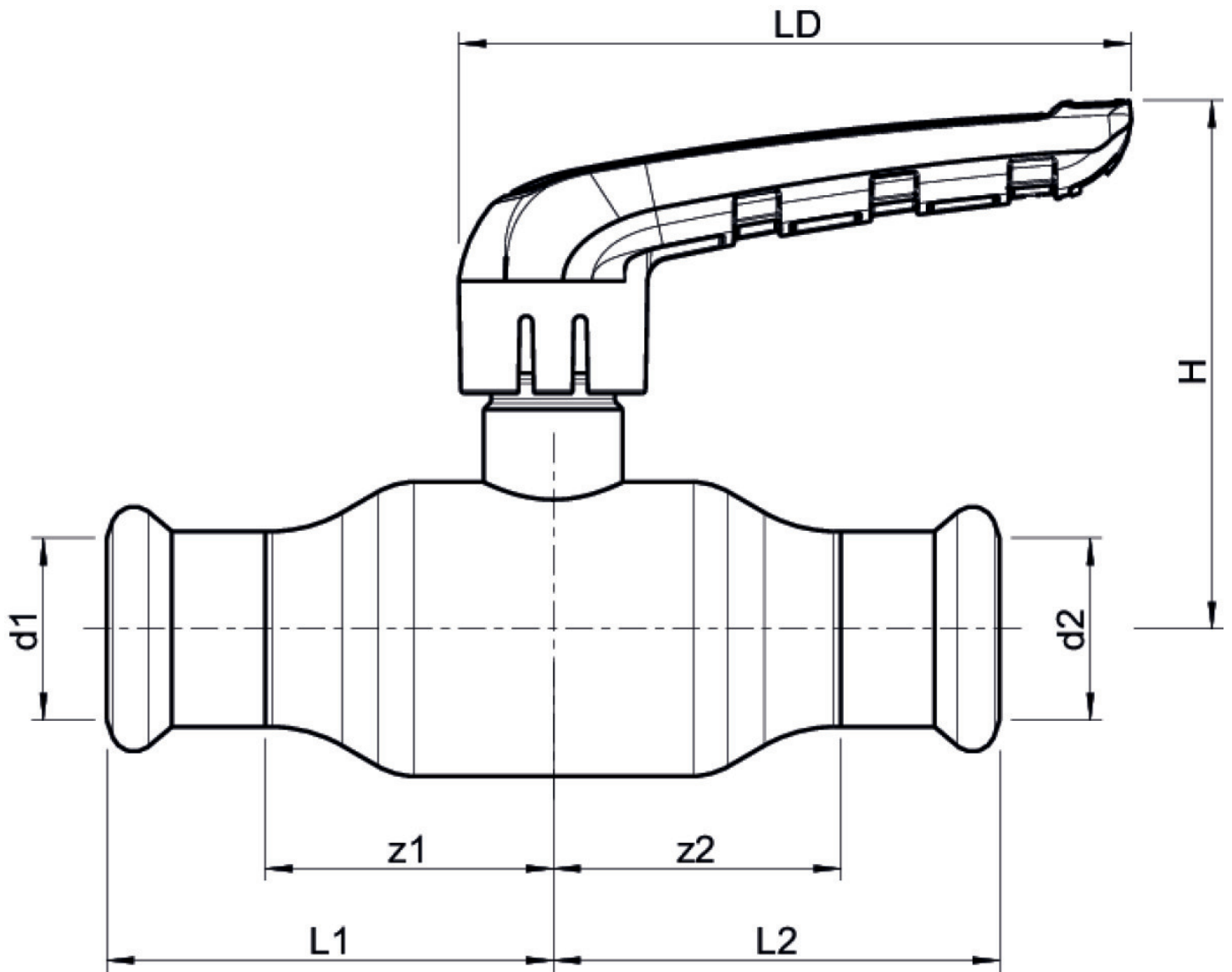

Art. No	label	d1 mm	d2 mm	L1 mm	L2 mm	z1 mm	z2 mm
54728BB0	15	15	15	47	47	27	27