

# STEEL FIX C-STAHL

CP487 C-Steel press-adaptor flange PN6 76-DN65 4-hole

54753J00

## Areas of application

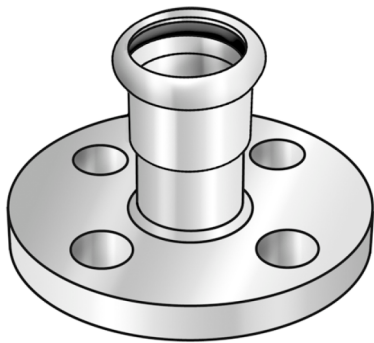

Press-fit adaptor flange, flat-sealing made of carbon steel coated with a zinc layer, incl. EPDM sealing components, d15-54 "leak before pressed"

hole circle dimensioning conforming to DIN 2501-PN6

Press contour: M

# Specifications

## Article information

port 1	Pressmuffe
port 2	Flansch
execution	1-teilig
design	gerade
press contour	M

## Technical properties

PN	PN 16
----	-------

## Product information

VPE1	1 SA1
weight	3,55 KGM
text	C-Steel press-adaptor flange PN6
INTRNR	73079980
main material group	STEELFIX
material group	C-STAHL pressfittings
code	CP487

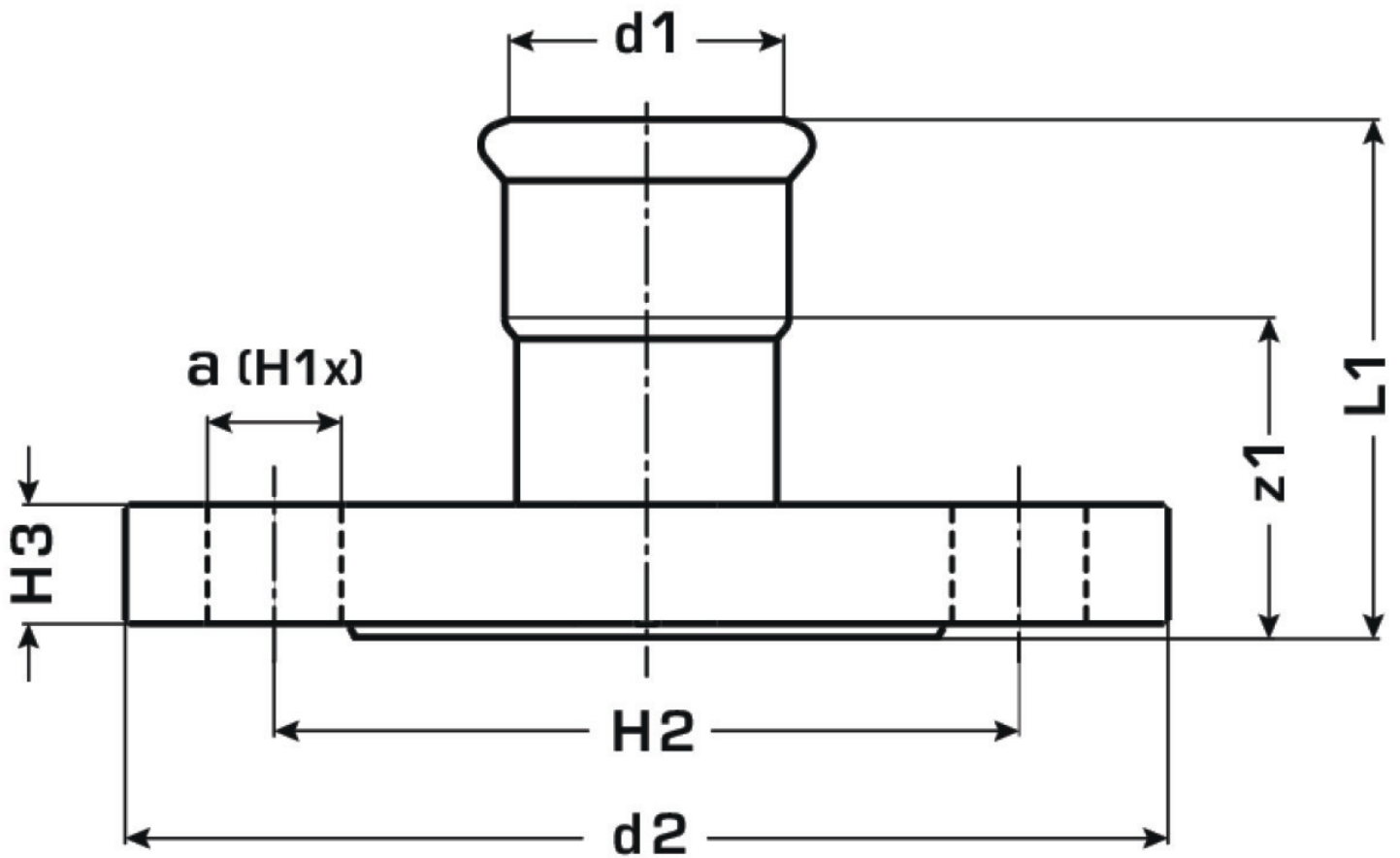

Art. No	label	d2	d1 mm	L1 mm	z1 mm	number of holes	pitch circle diameter mm
54753J00	76-DN65 4-hole	DN 65	76.1	94	39	4	130