

STEEL FIX EDELSTAHL

NP453 STEELFIX stainless steel press-fit ball valve 28

53728EE0

Areas of application



Press-fit ball valve with full passage, ball and base body with full flow, made of stainless steel 1.4404, incl. EPDM sealing elements, "leak before pressed"

Press contour: M

Operating temperature: - 35°C - tmax 135°C

Approvals:



Specifications

Article information

port 1	Pressmuffe
port 2	Pressmuffe
execution	gerade

Product information

VPE1	1,00 SA1
VPE2	10,00 KT1
weight	0,560 KGM
text	STEELFIX stainless steel press-fit ball valve
INTRNR	84818081
material group	EDELSTAHL pressfittings
code	NP453

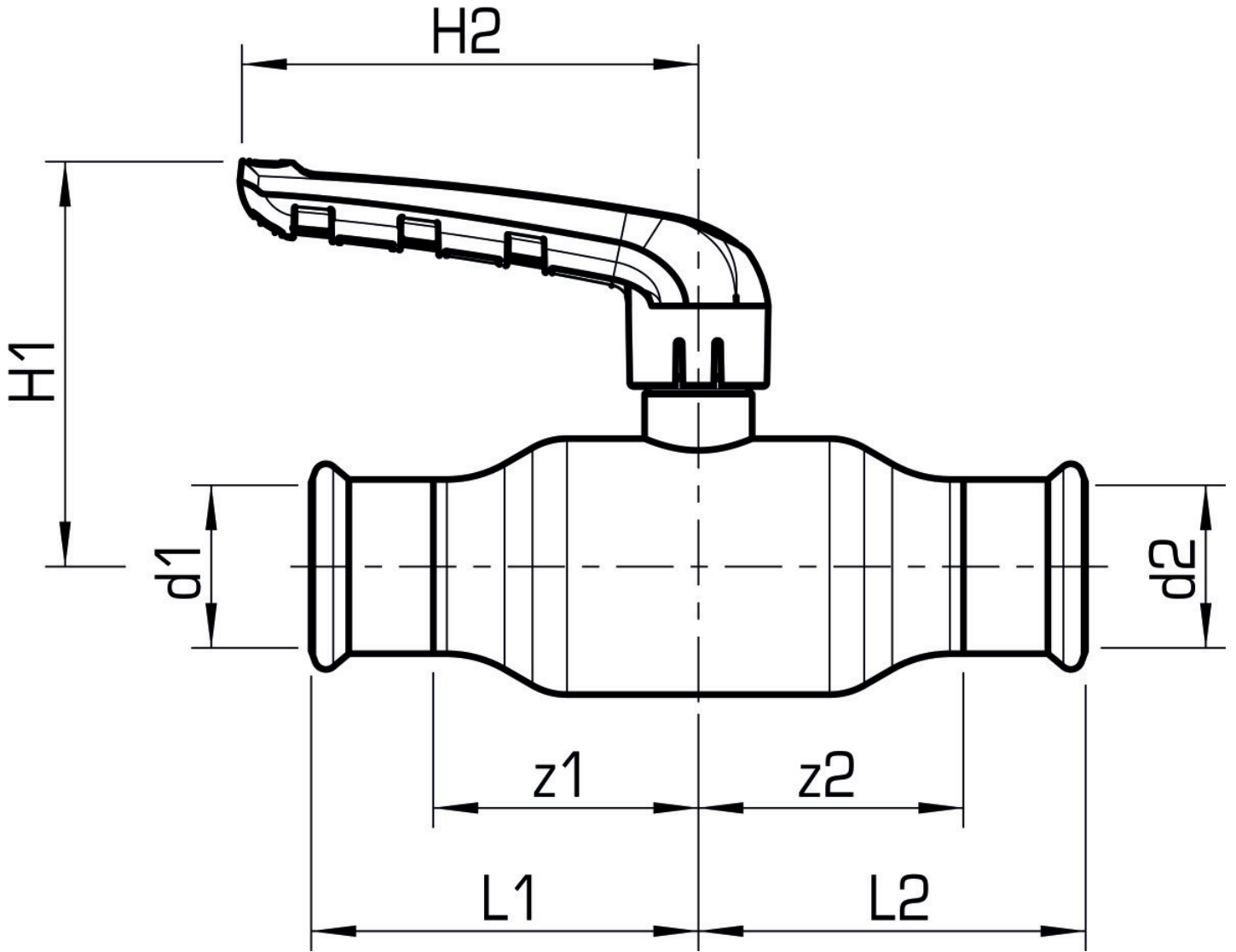

Art. No	label	d1 mm	d2 mm	L1 mm	L2 mm	z1 mm	z2 mm
53728EE0	28	28	28	70	70	45	45