

COPPER FIX

COF486 COPPERFIX copper press-adapter
flange PN10/16 89-DN80 8-hole

52755K00

Areas of application

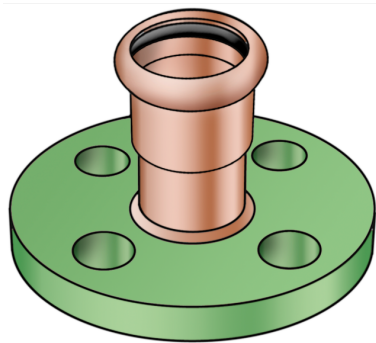

Press-adapter flange, flat-sealing made of red brass, incl. EPDM sealing elements, depending on the size with flat or grooved sealing surface, "leak before pressed"

Press contour: M

Flange dimensions conforming to DIN 2501 - PN16

Approvals:



Specifications

Article information

port 1	Pressmuffe
port 2	Flansch
design	gerade
press contour	M

Technical properties

PN	PN 16
----	-------

Product information

VPE1	1,00 KT1
weight	4,360 KGM
text	COPPERFIX copper press-adapter flange PN10/16
INTRNR	74122000
main material group	COPPERFIX
material group	KUPFER pressfittings
code	COF486

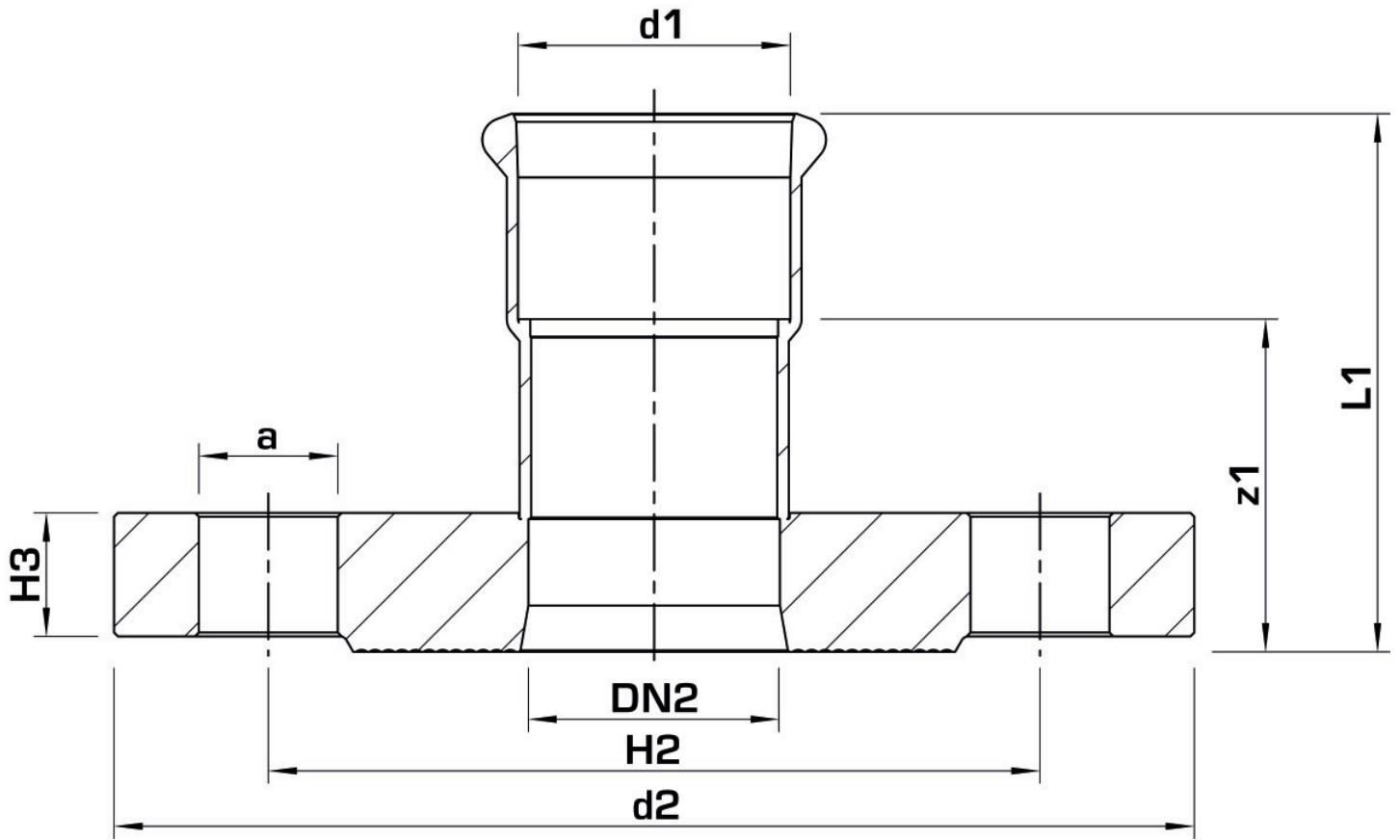

Art. No	label	d1 mm	L1 mm	z1 mm	pitch circle diameter mm
52755K00	89-DN80 8-hole	88,9	113	51	160