

STEEL FIX C-STAHl

CP410 STEELFIX carbon steel press-fit coupling
15

54600BB0

Areas of application



Press coupling straight made of carbon steel coated with a zinc layer, incl. EPDM sealing elements,
d15-54 "leak before pressed"

Press contour: M

Specifications

Article information

port 1	Pressmuffe
port 2	Pressmuffe
execution	1-part
design	gerade
press contour	M

Technical properties

maximum working pressure at 20 ° C	16 bar
------------------------------------	--------

Product information

VPE1	10,00 SA1
VPE2	140,00 KT1
VPE3	3500,00 DDP
weight	0,040 KGM
text	STEELFIX carbon steel press-fit coupling
INTRNR	73079980
main material group	STEELFIX
material group	C-STAHL pressfittings
code	CP410

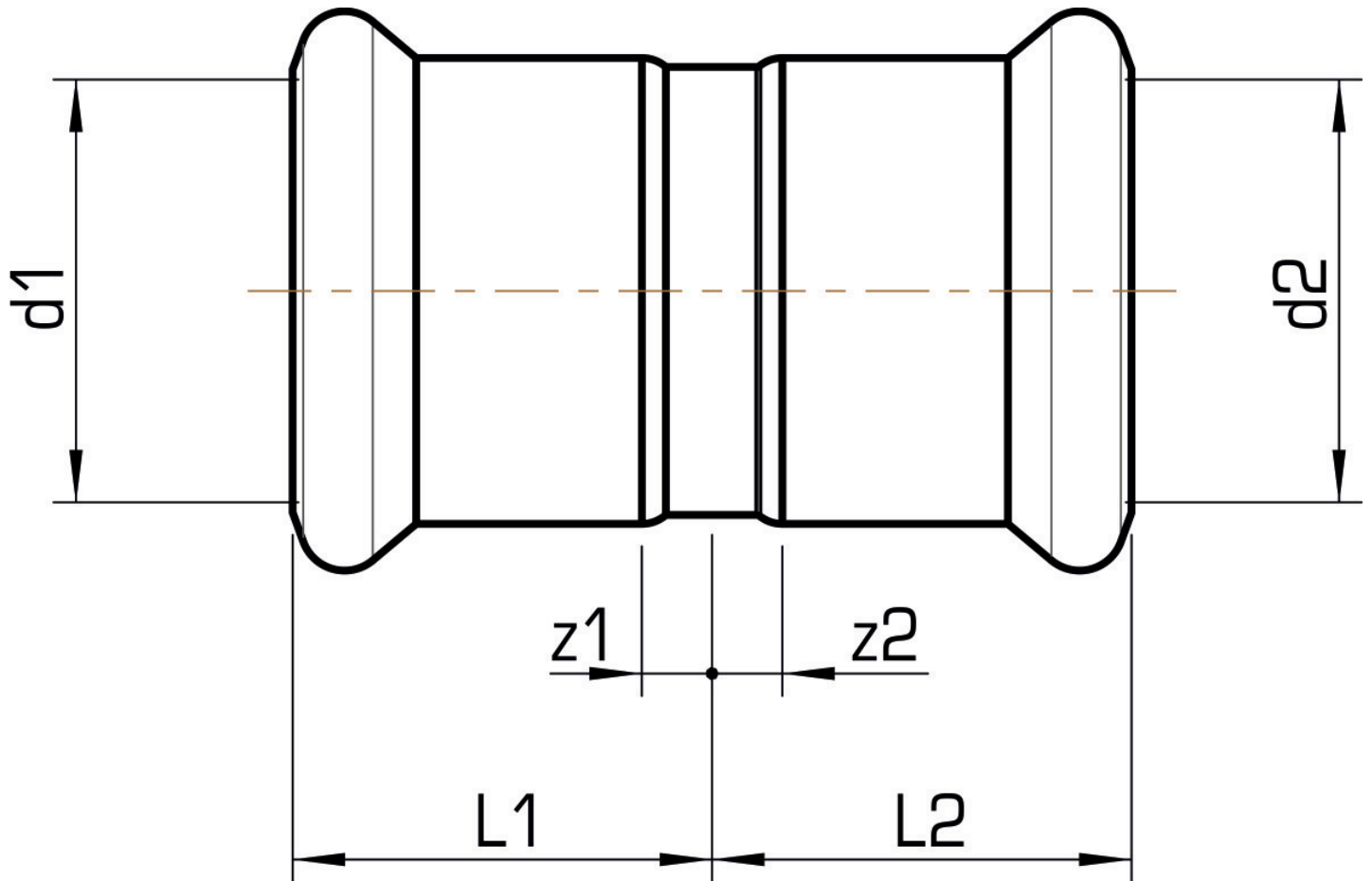

Art. No	label	d1 mm	d2 mm	L1 mm	L2 mm	z1 mm	z2 mm
54600BB0	15	15	15	25	25	5	5