

# STEEL FIX C-STAHL

CP460 STEELFIX carbon steel press-fit-adapter elbow 90° with male thread 18x1/2"

54712C02

## Areas of application

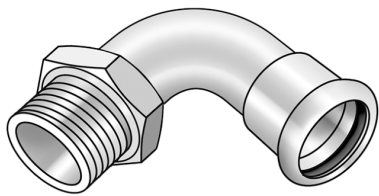

Press-elbow adapter 90° with male thread conforming to EN 10226-1 made of carbon steel coated with a zinc layer, incl. EPDM sealing components, d15-54 "leak before pressed"

Press contour: M

# Specifications

## Article information

port 1	Pressmuffe
port 2	Außengewinde konisch (NPT)
execution	1-part
design	Bogen
angle	90 °
press contour	M

## Technical properties

maximum working pressure at 20 ° C	16 bar
------------------------------------	--------

## Product information

VPE1	10,00 SA1
VPE2	60,00 KT1
VPE3	1500,00 DDP
weight	0,083 KGM
text	STEELFIX carbon steel press-fit-adapter elbow 90° with male thread
INTRNR	73079980
main material group	STEELFIX
material group	C-STAHL pressfittings
code	CP460

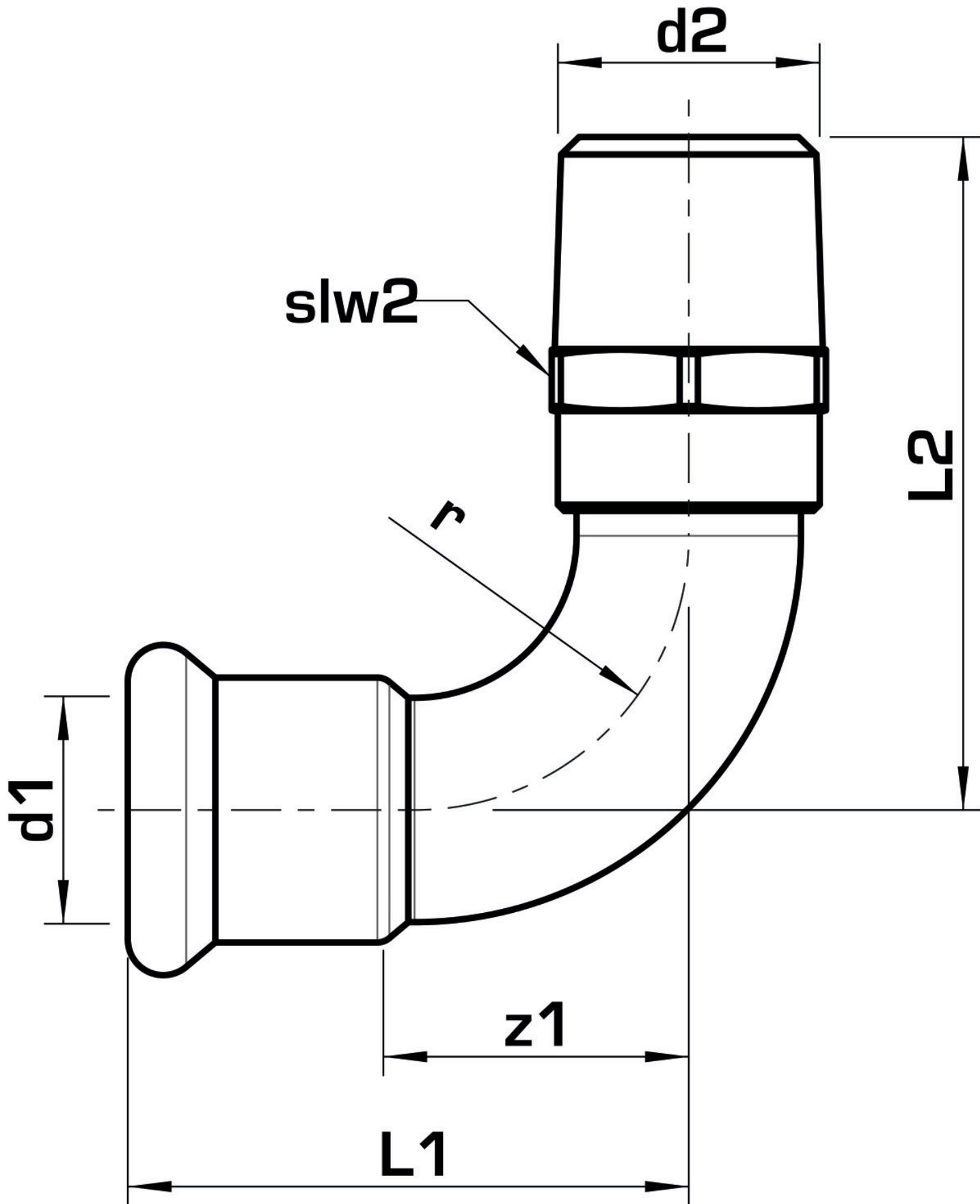

Art. No	label	d2 Inches	d1 mm	L1 mm	L2 mm	z1 mm	slw2 mm
54712C02	18x1/2"	1/2" (15)	18	45	54	25	22



**KE KELIT GmbH**

A 4020 Linz, Ignaz-Mayer-Straße 17, Austria, Europe

**PHONE** +43 (0) 50 779 **E-MAIL** [office@kekelit.com](mailto:office@kekelit.com)

[www.kekelit.com](http://www.kekelit.com)