

# STEEL FIX C-STAHL

CP466 STEELFIX carbon steel press-fit union with female thread 35x5/4"

54742F06

## Areas of application

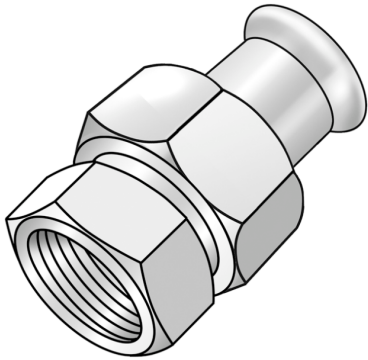

Press-fit union with female thread conforming to EN 10226-1 made of carbon steel coated with a zinc layer, incl. EPDM sealing elements, d15-54 "leak before pressed"

Press contour: M

# Specifications

## Article information

port 1	Pressmuffe
port 2	Innengewinde zylindrisch BSPT-Rp (ISO 7-1 / EN 10226-1)
execution	1-part
design	gerade
press contour	M

## Technical properties

maximum working pressure at 20 ° C	16 bar
------------------------------------	--------

## Product information

VPE1	2,00 SA1
VPE2	16,00 KT1
weight	0,440 KGM
text	STEELFIX carbon steel press-fit union with female thread
INTRNR	73079980
main material group	STEELFIX
material group	C-STAHl pressfittings
code	CP466

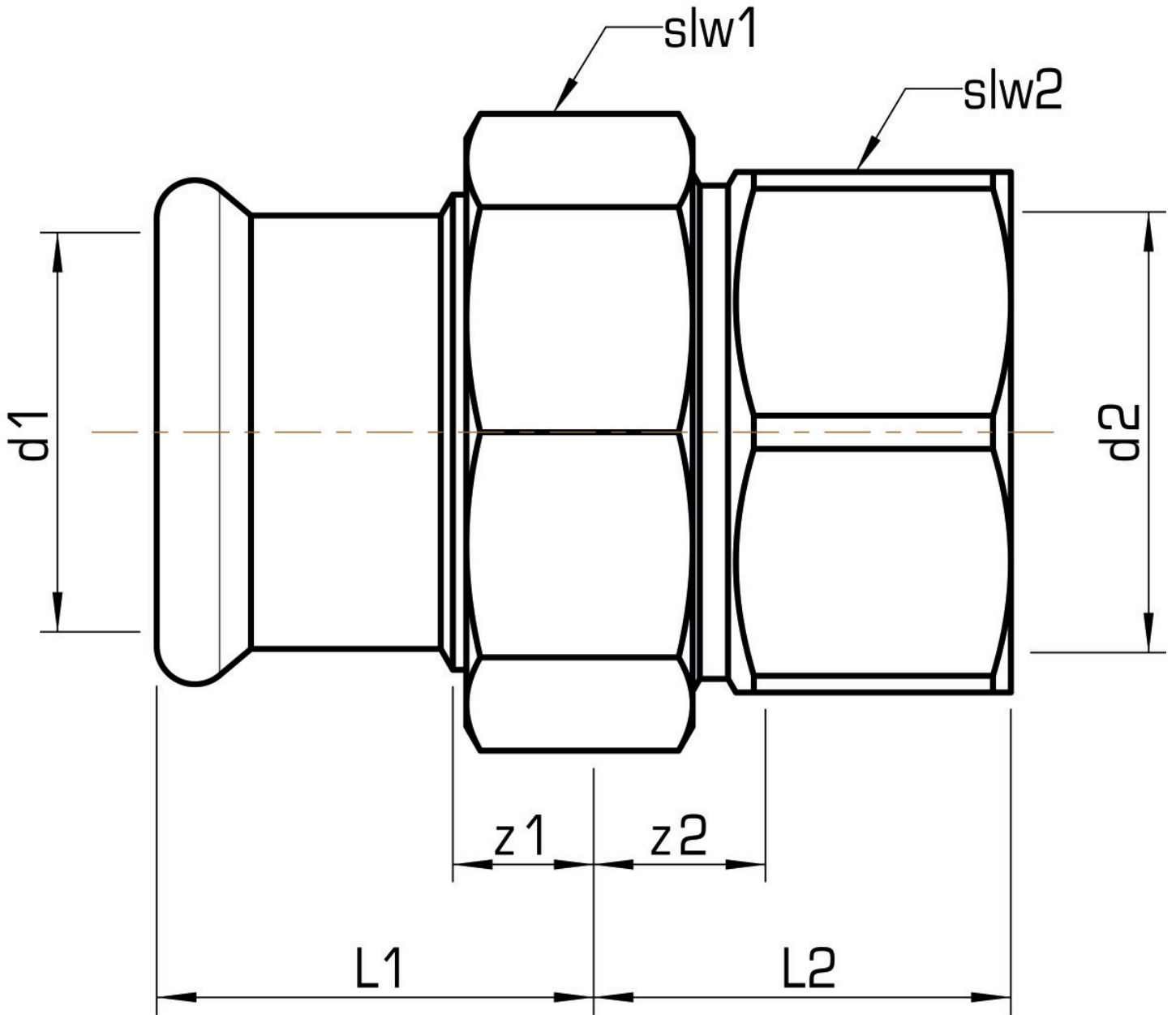

Art. No	label	d2 Inches	d1 mm	L1 mm	L2 mm	z1 mm	z2 mm	slw1 mm	slw2 mm
54742F06	35x5/4"	1 1/4"	35	38,5	37	12,5	15,5	52	50