

STEEL FIX EDELSTAHL

NPI486 STEELFIX industrial stainless steel press-fit adapter flange PN10/16 76-DN65 4-hole

53855J00

Areas of application

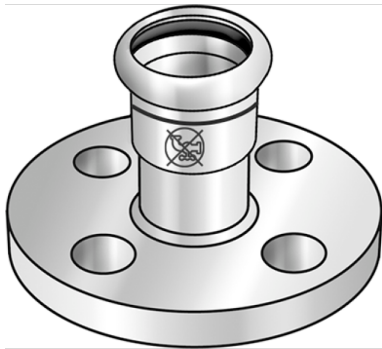

Press-adapter flange, flat-sealing made of 1.4301 stainless steel, depending on the size with flat or grooved sealing surface, incl. EPDM sealing elements, d15-54 "leak before pressed"

Hole circle dimensioning conforming to DIN 2501-PN16

Press contour: M

ATTENTION: NOT suitable for drinking water!

Specifications

Article information

port 1	Pressmuffe
port 2	Flansch
execution	1-teilig
design	gerade
press contour	M

Technical properties

PN	PN 16
----	-------

Product information

VPE1	1,00 SA1
VPE2	10,00 KT1
weight	3,350 KGM
text	STEELFIX industrial stainless steel press-fit adapter flange PN10/16
INTRNR	73072980
code	NPI486

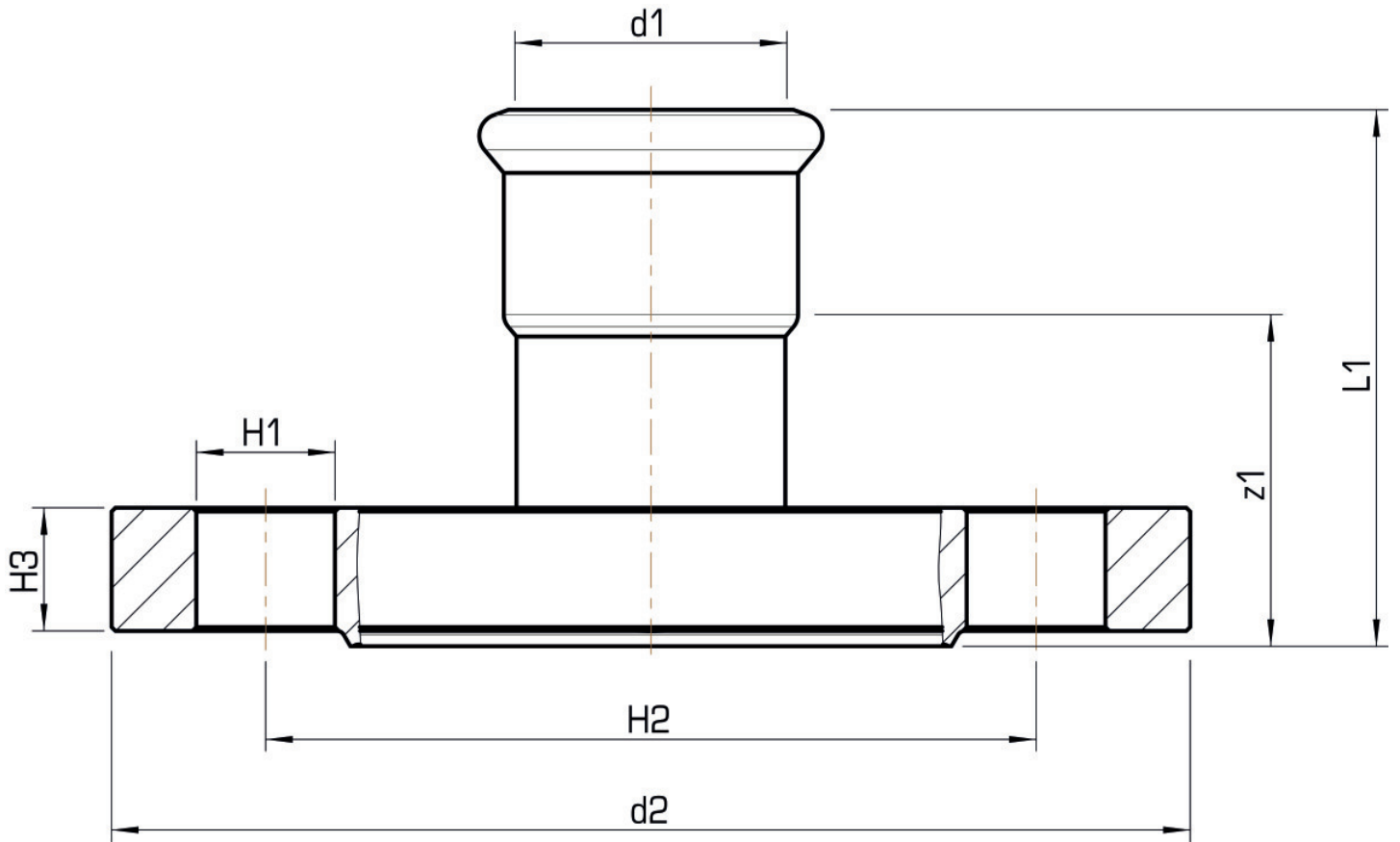

Art. No	label	d2	d1 mm	L1 mm	z1 mm	pitch circle diameter mm
53855J00	76-DN65 4-hole	DN 65	76,1	126	71	145