

# KELEN

## KE44 KELEN saddle fitting male 40-50x1/2"

2477051

### Areas of application

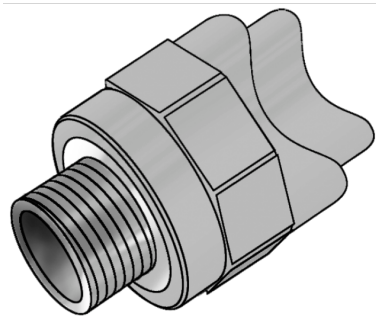

KELEN polyfusion weld fitting for connecting pipes with fittings made of the same material without narrowing the cross-section, with injected male thread made of dezincification-resistant brass and non-porous metal-plating, thread conforms to ÖNORM EN 10226. For welding directly to pipelines that have already been installed; the welding is carried out with a WZ124 saddle welding tool

### Approvals:



# Specifications

Product information	
VPE1	5,00 SA1
VPE2	80,00 KT1
VPE3	320,00 KT2
VPE4	7680,00 PAL
weight	0,074 KGM
text	KELEN saddle fitting male
INTRNR	39174000
main material group	KELEN
material group	KELEN metal fittings
code	KE44

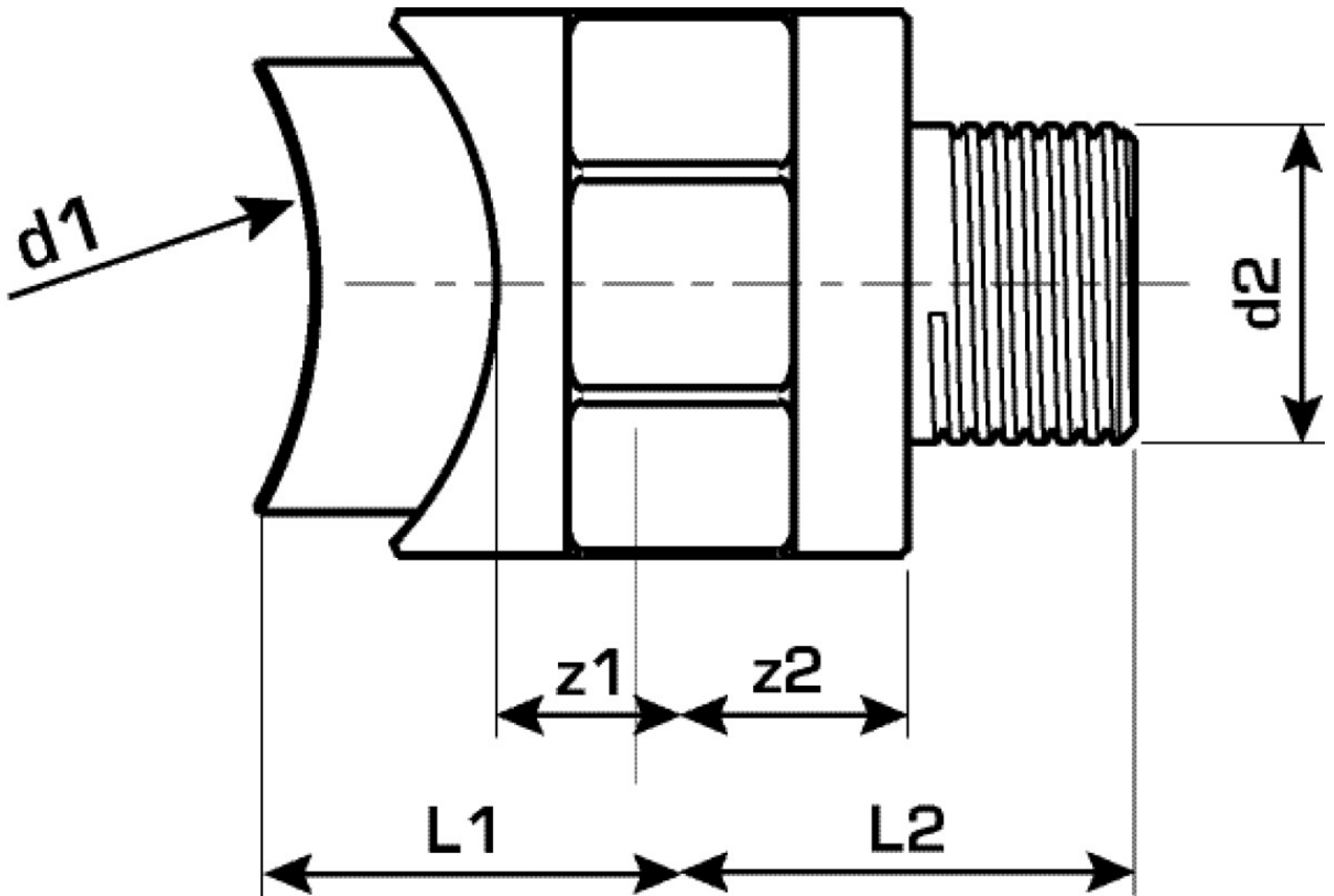

Art. No	label	d	L2 mm	z1 mm	z2 mm
2477051	40-50x1/2"	1/2" (15)	30	13	15