

KELEN

K50S KELIT standard extension 1/2" and 3/4"

2661050

Areas of application

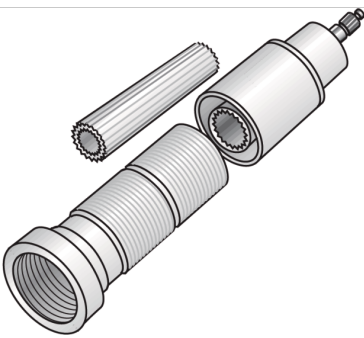

Adjustable extension piece without transparent components up to 150mm, compatible with KE50 and K50C

Approvals:



KE KELIT GmbH

A 4020 Linz, Ignaz-Mayer-Straße 17, Austria, Europe

PHONE +43 (0) 50 779 E-MAIL office@kekelit.com

www.kekelit.com

Specifications

Product information

VPE1	1,00 SA1
VPE2	20,00 KT1
VPE3	80,00 KT2
VPE4	1920,00 PAL
weight	0,168 KGM
text	KELIT standard extension
INTRNR	84819000
main material group	KELEN
material group	KELEN accessories
code	K50S

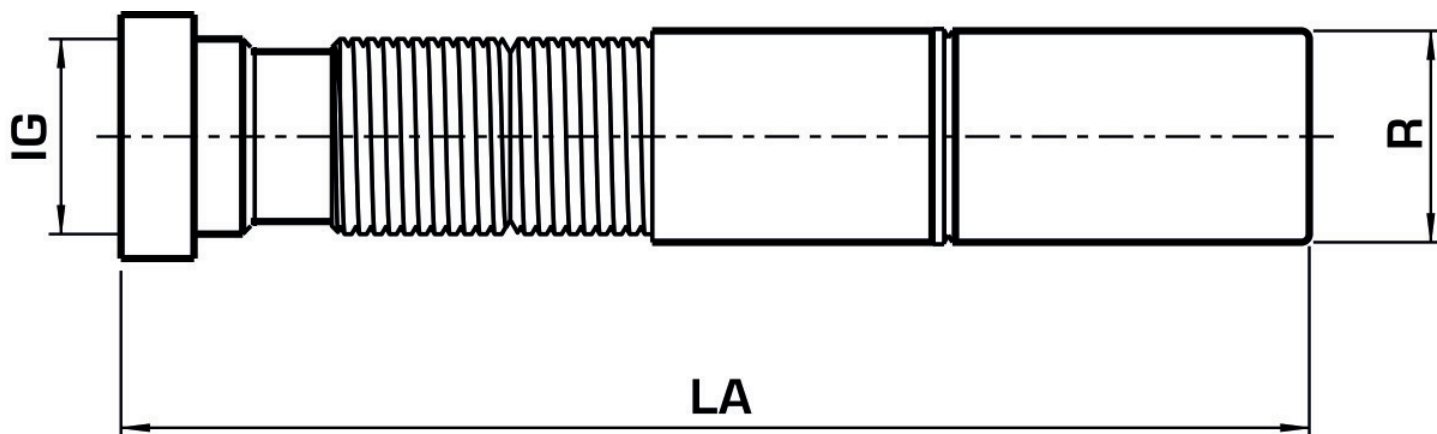

Art. No	label	d1 mm	L1 mm
2661050	1/2" and 3/4"	26	150