

STEEL FIX C-STAHL

CP451 STEELFIX carbon steel press-fit union with male thread 28x1"

54741E05

Areas of application

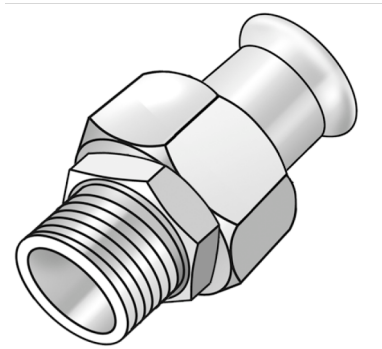

Press-fit union with male thread conforming to EN 10226-1 made of carbon steel coated with a zinc layer, incl. EPDM sealing elements, d15-54 "leak before pressed"

Press contour: M

Specifications

Article information

port 1	Pressmuffe
port 2	Außengewinde konisch (NPT)
execution	1-part
design	gerade
press contour	M

Technical properties

maximum working pressure at 20 ° C	16 bar
------------------------------------	--------

Product information

VPE1	2,00 SA1
VPE2	30,00 KT1
VPE3	750,00 DDP
weight	0,322 KGM
text	STEELFIX carbon steel press-fit union with male thread
INTRNR	73079980
main material group	STEELFIX
material group	C-STAHL pressfittings
code	CP451

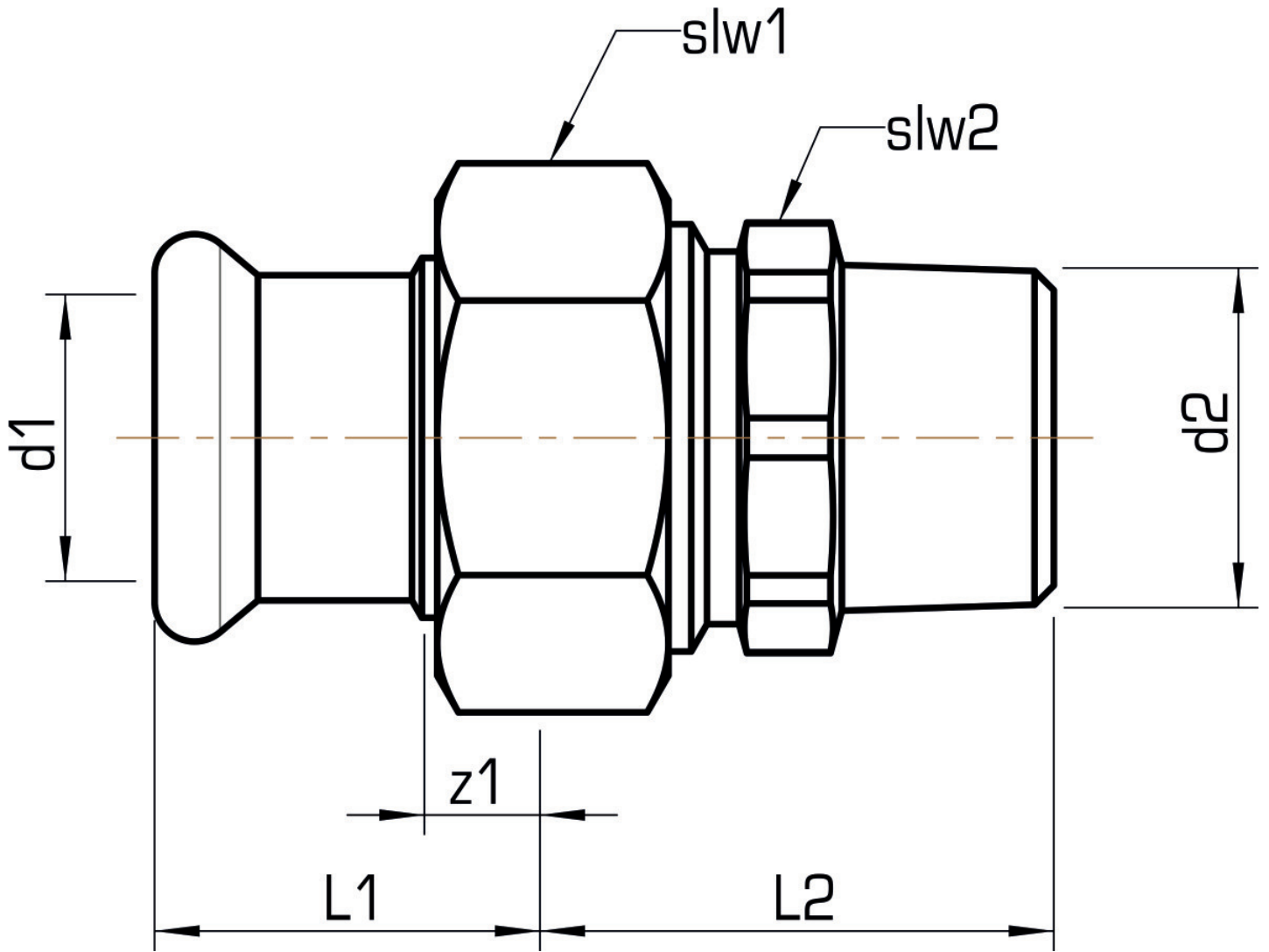

Art. No	label	d2 Inches	d1 mm	L1 mm	L2 mm	z1 mm	slw1 mm	slw2 mm
54741E05	28x1"	1"	28	32	42,5	9	46	39