

# KETRIX

## TRI31 KETRIX tee with male thread branch 25x3/4"

55218E04

### Areas of application

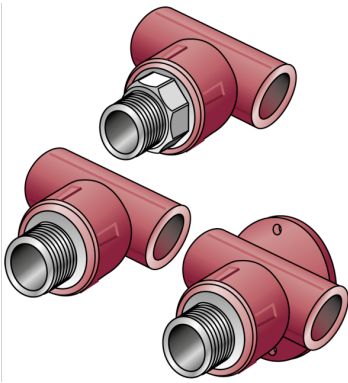

KETRIX polyfusion weld fitting for connecting POB pipes with fittings made of the same material without narrowing the cross-section, with injected male thread made of dezincification-resistant brass and non-porous metal plating, thread conforms to ÖNORM EN 10226

System parts marked with an "S" are produced with a wrench attachment connection

# Specifications

## Technical properties

maximum working pressure at 20 ° C	16 bar
------------------------------------	--------

## Product information

VPE1	10,00 SA1
VPE2	40,00 KT1
VPE3	160,00 KT2
VPE4	3840,00 PAL
weight	0,158 KGM
text	KETRIX tee with male thread branch
INTRNR	39174000
main material group	KETRIX
material group	KETRIX metal fittings
code	TRI31

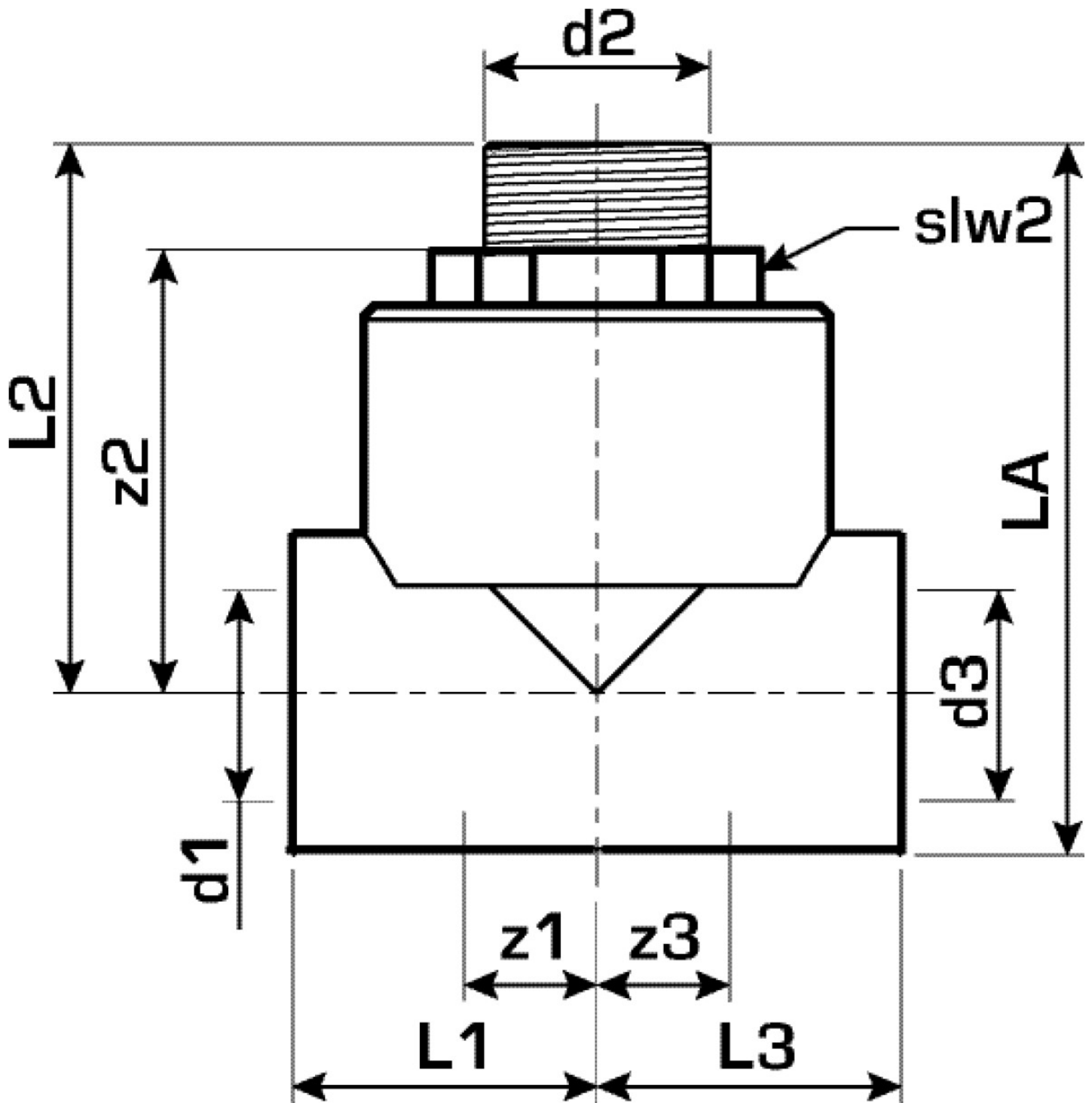

Art. No	label
55218E04	25x3/4"