

KETRIX

TRI31 KETRIX tee with male thread branch 32x1"S

55218F05

Areas of application

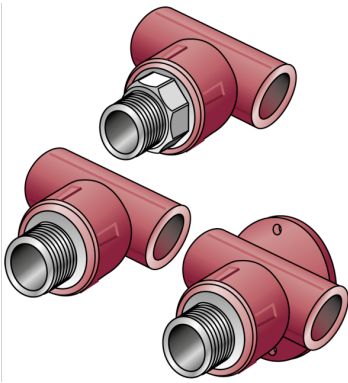

KETRIX polyfusion weld fitting for connecting POB pipes with fittings made of the same material without narrowing the cross-section, with injected male thread made of dezincification-resistant brass and non-porous metal plating, thread conforms to ÖNORM EN 10226

System parts marked with an "S" are produced with a wrench attachment connection

Specifications

Technical properties

maximum working pressure at 20 ° C 16 bar

Product information

VPE1 5,00 SA1

VPE2 20,00 KT1

VPE3 80,00 KT2

VPE4 1920,00 PAL

weight 0,322 KGM

text KETRIX tee with male thread branch

INTRNR 39174000

main material group KETRIX

material group KETRIX metal fittings

code TRI31

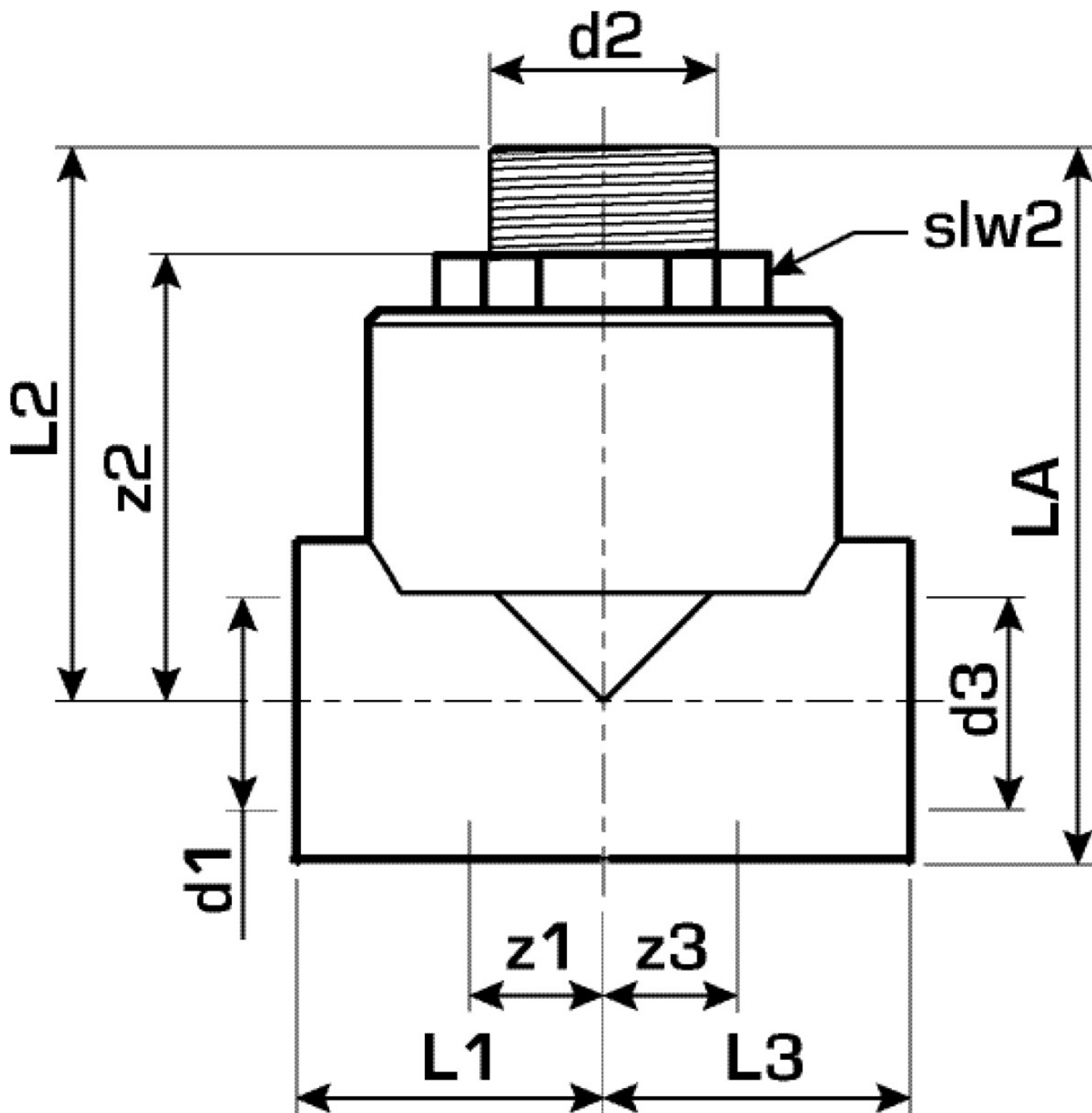

Art. No	label
55218F05	32x1"S