

KELEN

KE31LA KELEN PP-RCT hollow wall tee male branch 20x1/2"BF/50

2643701

Areas of application

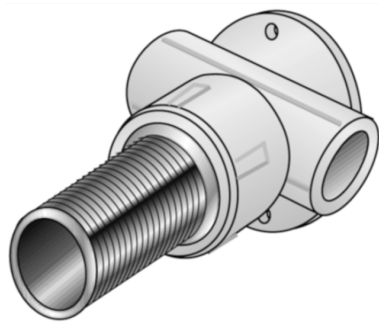

KELEN PP-RCT Polyfusion welding fitting for connecting pipes with fittings made of the same material (no reduction of internal diameter), with injected male thread made of dezincification-resistant brass, non-porous metal plating, thread conforms to ÖNORM EN 10226, on the metal side extended by 50mm

Approvals:



Specifications

Article information

port 1	Kunststoffschweißmuffe
port 2	Innengewinde konisch (NPT)
port 3	Kunststoffschweißmuffe
execution	T-Stück
angle	90 °

Technical properties

maximum working pressure at 20 ° C	20 bar
------------------------------------	--------

Product information

VPE1	5,00 SA1
weight	0,154 KGM
text	KELEN PP-RCT hollow wall tee male branch
INTRNR	39174000
main material group	KELEN
material group	KELEN metal fittings
code	KE31LA

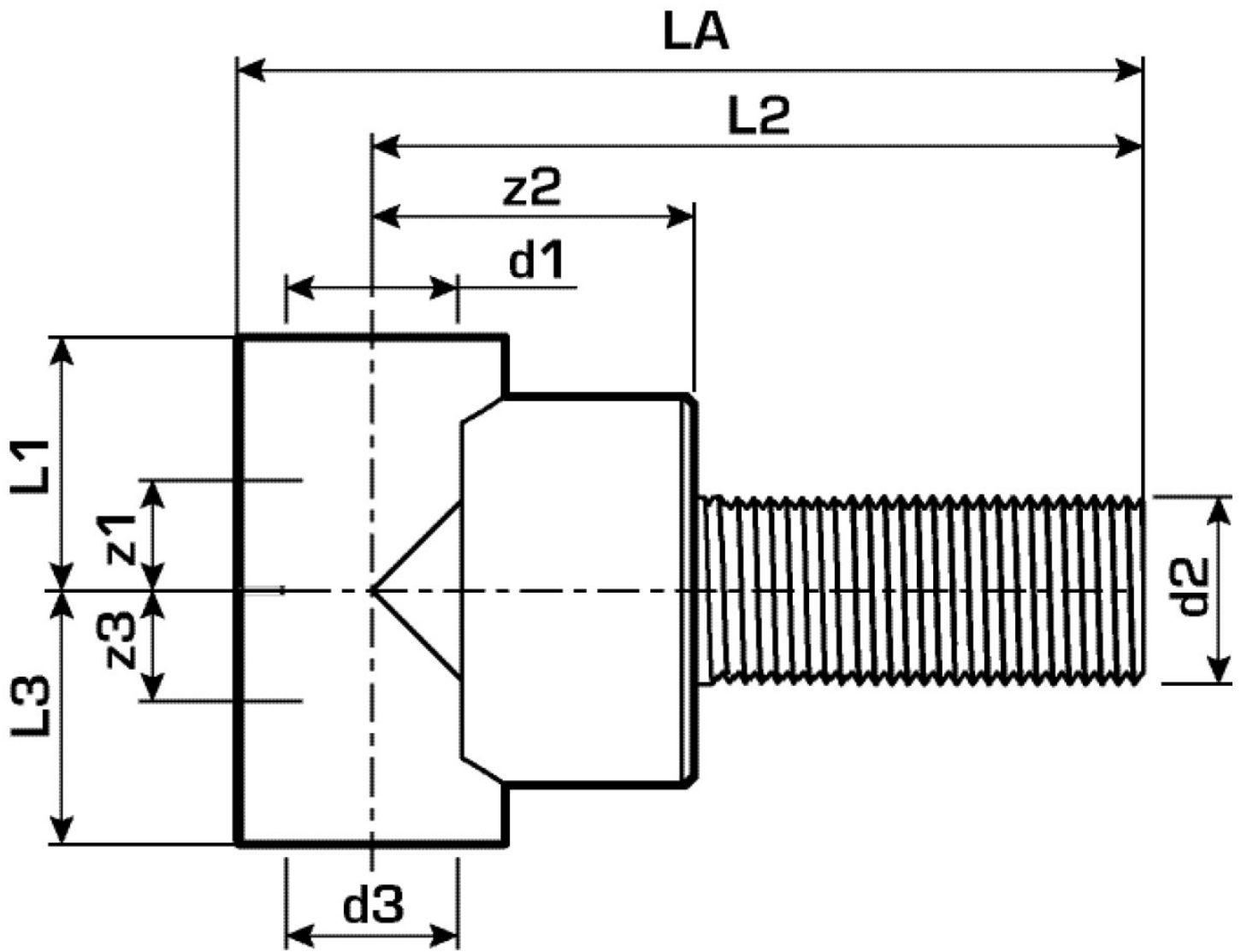

Art. No	label	d2	d1 mm	d3 mm	L1 mm	L1 mm	L2 mm	L3 mm	z1 mm	z2 mm	z3 mm
2643701	20x1/2"B	1/2" (15)	20	20	98	28	84	28	12	35	12