

# KELOX

## KMU451 KELOX-ULTRAX union with male thread 25x1"

71241E05

### Areas of application

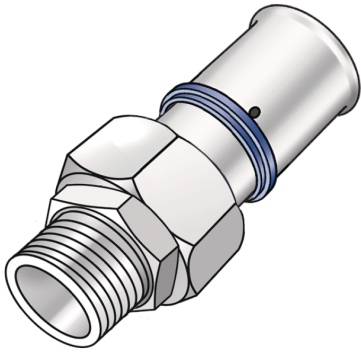

ULTRAX press-fit union with male thread made from stainless steel, thread as per ÖNORM EN 10226, for connecting to fittings made of non-porous metallised brass; incl. support sleeves with O-rings and stainless steel press-fit sleeves "leak before pressed", flat-sealing including seal

### Approvals:



# Specifications

## Article information

port 1	Pressmuffe
port 2	Außengewinde konisch (NPT)
execution	2-part
design	Straight
press contour	U

## Technical properties

maximum working pressure at 20 ° C	10 bar
------------------------------------	--------

## Product information

VPE1	10,00 SA1
VPE2	50,00 KT1
weight	0,227 KGM
text	KELOX-ULTRAX union with male thread
INTRNR	74122000
main material group	KELOX
material group	KELOX-ULTRAX metal fittings
code	KMU451



Art. No	label	d2 Inches	d1 mm	L1 mm	L2 mm	z1 mm	z2 mm	slw1 mm	slw2 mm
71241E05	25x1"	1"	25	52	20	21	40	38	39