

# KELOX

## KMU452 KELOX-ULTRAX slanted-seat valve 16-DN15

71233BB0

### Areas of application

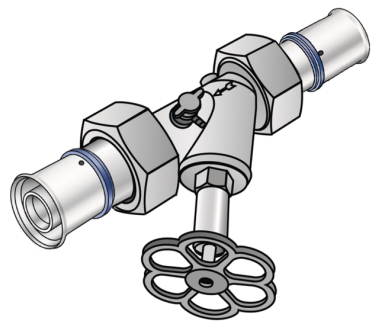

Slanted-seat valve with ULTRAX press-fit unions KMU455 top part free of dead space, flat-sealing incl. seal and drain outlet "leak before pressed"

### Approvals:



# Specifications

## Product information

VPE1	1 SA1
weight	0,49 KGM
text	KELOX-ULTRAX slanted-seat valve
INTRNR	74122000
main material group	KELOX
material group	KELOX-ULTRAX metal fittings
code	KMU452

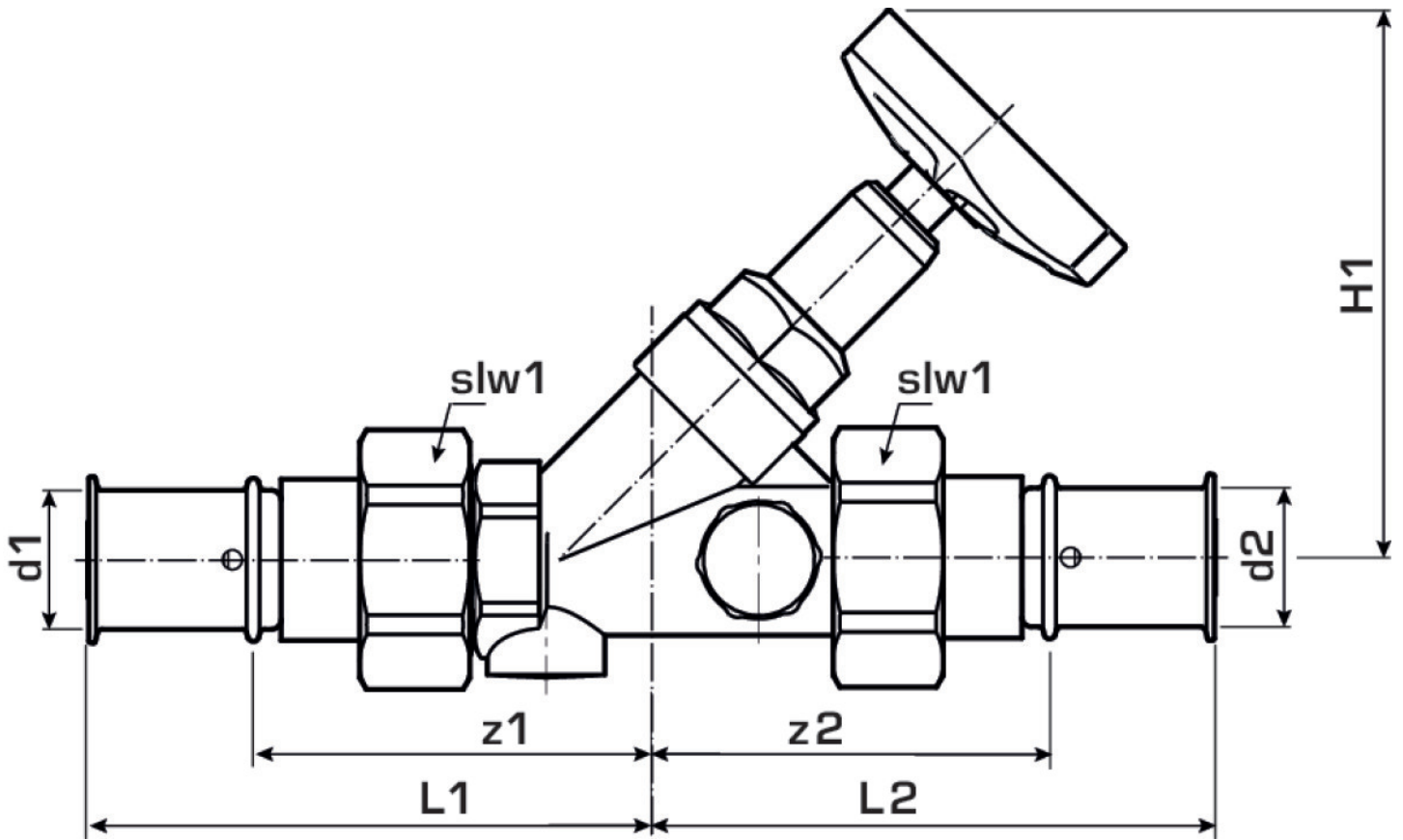

Art. No	label	L1	L2	z1	z2	slw1
71233BB0	16-DN15	81	81	52	58	49