

KETRIX

TRI43 KETRIX saddle fitting with female thread 63-125x1/2"

55213K02

Areas of application

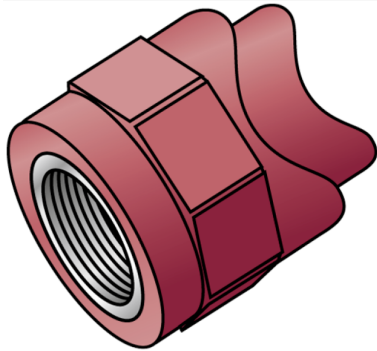

KETRIX polyfusion weld fitting for connecting POB pipes with fittings made of the same material without narrowing the cross-section, injected female thread made of dezincification-resistant brass and non-porous metal-plating, thread conforms to DIN EN 10226. For welding directly to pipelines that have already been installed; the welding is carried out with a WZ124 saddle welding tool
Do NOT connect to threaded pipes or to cast iron fittings!

Specifications

Product information	
VPE1	5,00 SA1
VPE2	80,00 KT1
VPE3	320,00 KT2
VPE4	7680,00 PAL
weight	0,069 KGM
text	KETRIX saddle fitting with female thread
INTRNR	39174000
main material group	KETRIX
material group	KETRIX metal fittings
code	TRI43



Art. No

label

55213K02

63-125x1/2"



KE KELIT GmbH

A 4020 Linz, Ignaz-Mayer-Straße 17, Austria, Europe

PHONE +43 (0) 50 779 E-MAIL office@kekelit.com

www.kekelit.com

3/3

18.12.2024