

WZ110 KELIT pipe welding machine 25-125

2680700

Areas of application

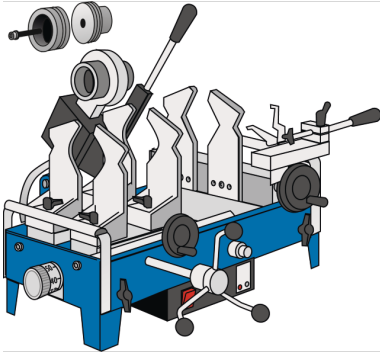

Pre-set, self-regulating pipe welding machine WZ110 d20-90:

with (230 V, 1000 W) welding mirror, heating elements d20-90mm

incl. pipe clamping jaws, wheel pipe cutter d20-75 and d50-140mm, timer, special gloves, pipe rest and feet, packaged in a wooden crate for transportation

Pre-set, self-regulating pipe welding machine WZ110 d25-125:

with (230 V, 1400 W) welding mirror, heating elements d25-125mm

incl. pipe clamping jaws wheel pipe cutter d20-75 and d50-140mm, timer, special gloves, pipe rest and feet, packaged in a wooden crate for transportation

Pre-set, self-regulating pipe welding machine WZ110 d63-160:

with (230 V, 3600 W) welding mirror, heating elements d63-160mm

incl. pipe clamping jaws d63-160mm, packaged in a wooden crate for transportation

Specifications

Product information	
VPE1	1 KST
weight	106 KGM
text	KELIT pipe welding machine
INTRNR	85158090
main material group	TOOLS
material group	KELEN, KETRIX tools
code	WZ110

Art. No	label
2680700	25-125