

KELOX

KMP480LX KELOX-PROTEC CLIX Wandscheibe mit IG 20mm 20x1/2"

730251D02

Areas of application

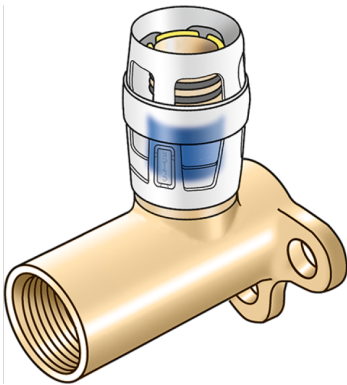

Steck-Wandscheibe mit IG um 20mm verlängert, aus entzinkungsbeständigem Messing (DZR), inkl. Stechhülse aus transparentem Polyamid mit Einschubklickgeräusch, sowie haptischem und optischem Einsteckindikator, O-Ringen, Auszugsbarrieren und Protectorring als Einschubsicherung
Gesamthöhe: 1/2" - 66mm
KEINE Gewinderohre und Tempergusfittings eindrehen!

Approvals:



Specifications

Article information

port 1	Einsteck (Push-Fitting)
design	Durchgängig rechtwinklig

Technical properties

maximum working pressure at 20 ° C	10 bar
---	--------

Product information

VPE1	10,00 SA1
VPE2	60,00 KT1
weight	0,200 KGM
text	KELOX-PROTEC CLIX Wandscheibe mit IG 20mm
INTRNR	74122000
main material group	KELOX
material group	KELOX-PROtec Steckformstücke
code	KMP480LX

