

KELOX

KMU410 KELOX-ULTRAX coupling 50/32

71100HF0

Areas of application

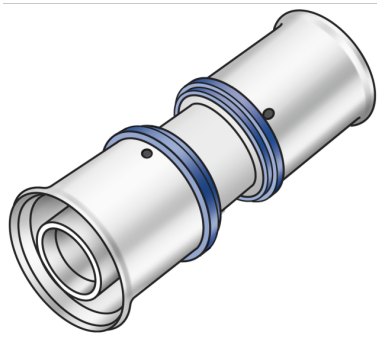

Press coupling equal or reduced, made of non-porous metallised brass, incl. support sleeves with O-rings and stainless steel press-fit sleeves, "leak before pressed"

Approvals:



KE KELIT GmbH

A 4020 Linz, Ignaz-Mayer-Straße 17, Austria, Europe

PHONE +43 (0) 50 779 E-MAIL office@kekelit.com

www.kekelit.com

Specifications

Article information

port 1	Pressing socket
port 2	Pressing socket
execution	1-part
design	Straight
press contour	U

Technical properties

maximum working pressure at 20 ° C	10 bar
------------------------------------	--------

Product information

VPE1	1,00 SA1
VPE2	25,00 KT1
weight	0,415 KGM
text	KELOX-ULTRAX coupling
INTRNR	74122000
main material group	KELOX
material group	KELOX-ULTRAX metal fittings
code	KMU410



Art. No	label	d1 mm	d2 mm	L1 mm	L2 mm	z1 mm	z2 mm
71100HF0	50/32	50	32	56	46	8	8,5