

STEELOX

SMX455K STEELOX fitting with female thread & wedge seal 16x1/2"

57204B02

Areas of application

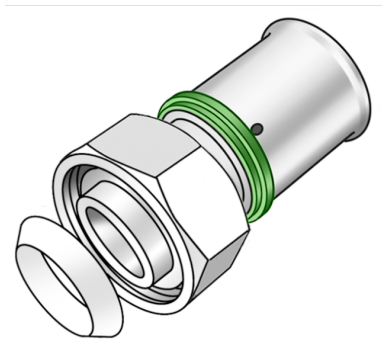

Press-fit union with female thread for connecting to fittings or threaded nipples made of non-porous metallised brass (CW724R), incl. support sleeves with O rings and stainless steel press-fit sleeves, "leak before pressed", incl. wedge seal

Approvals:



KE KELIT GmbH

A 4020 Linz, Ignaz-Mayer-Straße 17, Austria, Europe

PHONE +43 (0) 50 779 E-MAIL office@kekelit.com

www.kekelit.com

Specifications

Article information

port 1	Pressmuffe
port 2	Überwurfmutter
execution	1-part
design	gerade
press contour	SX

Technical properties

maximum working pressure at 20 ° C	10 bar
------------------------------------	--------

Product information

VPE1	10,00 SA1
VPE2	200,00 KT1
weight	0,095 KGM
text	STEELOX fitting with female thread & wedge seal
INTRNR	74122000
code	SMX455K

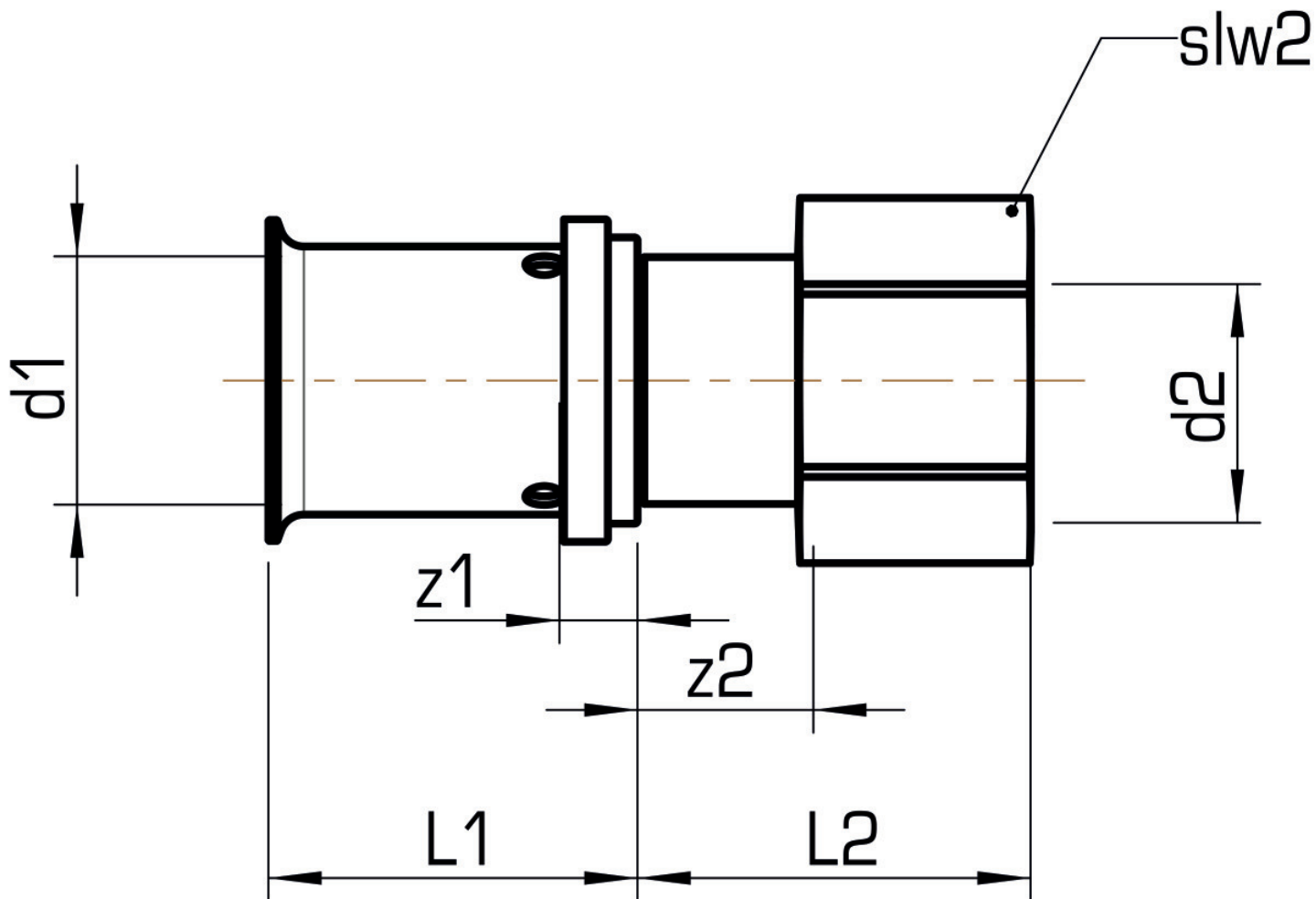

Art. No	label	d2 Inches	d1 mm	L1 mm	L2 mm	z1 mm	z2 mm	slw2 mm
57204B02	16x1/2"	1/2" (15)	16	33	14,5	10	4	24