

# STEELOX

SMX456K STEELOX 90° fitting with female thread & wedge seal 16x1/2"

57207B02

## Areas of application

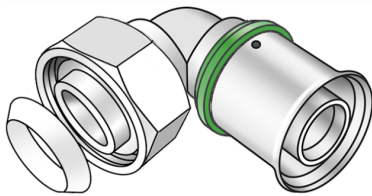

Press-fit elbow union 90° with female thread for connecting to fittings or threaded nipples made of non-porous metallised brass (CW724R), incl. support sleeves with O rings and stainless steel press-fit sleeves, "leak before pressed", incl. wedge seal

## Approvals:



KE KELIT GmbH

A 4020 Linz, Ignaz-Mayer-Straße 17, Austria, Europe

PHONE +43 (0) 50 779 E-MAIL [office@kekelit.com](mailto:office@kekelit.com)

[www.kekelit.com](http://www.kekelit.com)

# Specifications

## Article information

port 1	Pressmuffe
port 2	Überwurfmutter
execution	1-part
design	Winkel
angle	90 °
press contour	SX

## Technical properties

maximum working pressure at 20 ° C	10 bar
------------------------------------	--------

## Product information

VPE1	10,00 SA1
VPE2	120,00 KT1
weight	0,102 KGM
text	STEELOX 90° fitting with female thread & wedge seal
INTRNR	74122000
code	SMX456K

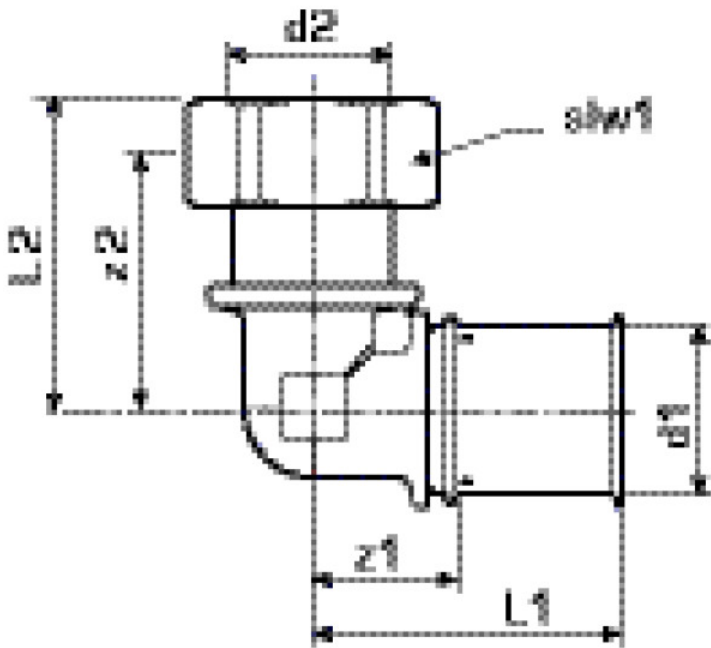

Art. No	label	d2	d1 mm	L1 mm	L2 mm	z1 mm	z2 mm	slw1 mm
57207B02	16x1/2"	1/2" (15)	16	38	39	16	2	24