

# STEEL FIX C-STAHl

CP420 C-Steel press-elbow 90° 54

54615HH0

## Areas of application



Press-elbow 90°, made of carbon steel coated with a zinc layer, incl. EPDM sealing elements, d15-54 "not pressed, not sealed"

Press contour: M

# Specifications

## Article information

port 1	Pressmuffe
port 2	Pressmuffe
execution	1-teilig
angle	90 °
press contour	M

## Technical properties

maximum working pressure at 20 ° C	16 bar
------------------------------------	--------

## Product information

VPE1	2 SA1
VPE2	6 KT1
VPE3	150 DDP
weight	0,489 KGM
text	C-Steel press-elbow 90°
INTRNR	73079980
main material group	STEELFIX
material group	C-STAHL pressfittings
code	CP420

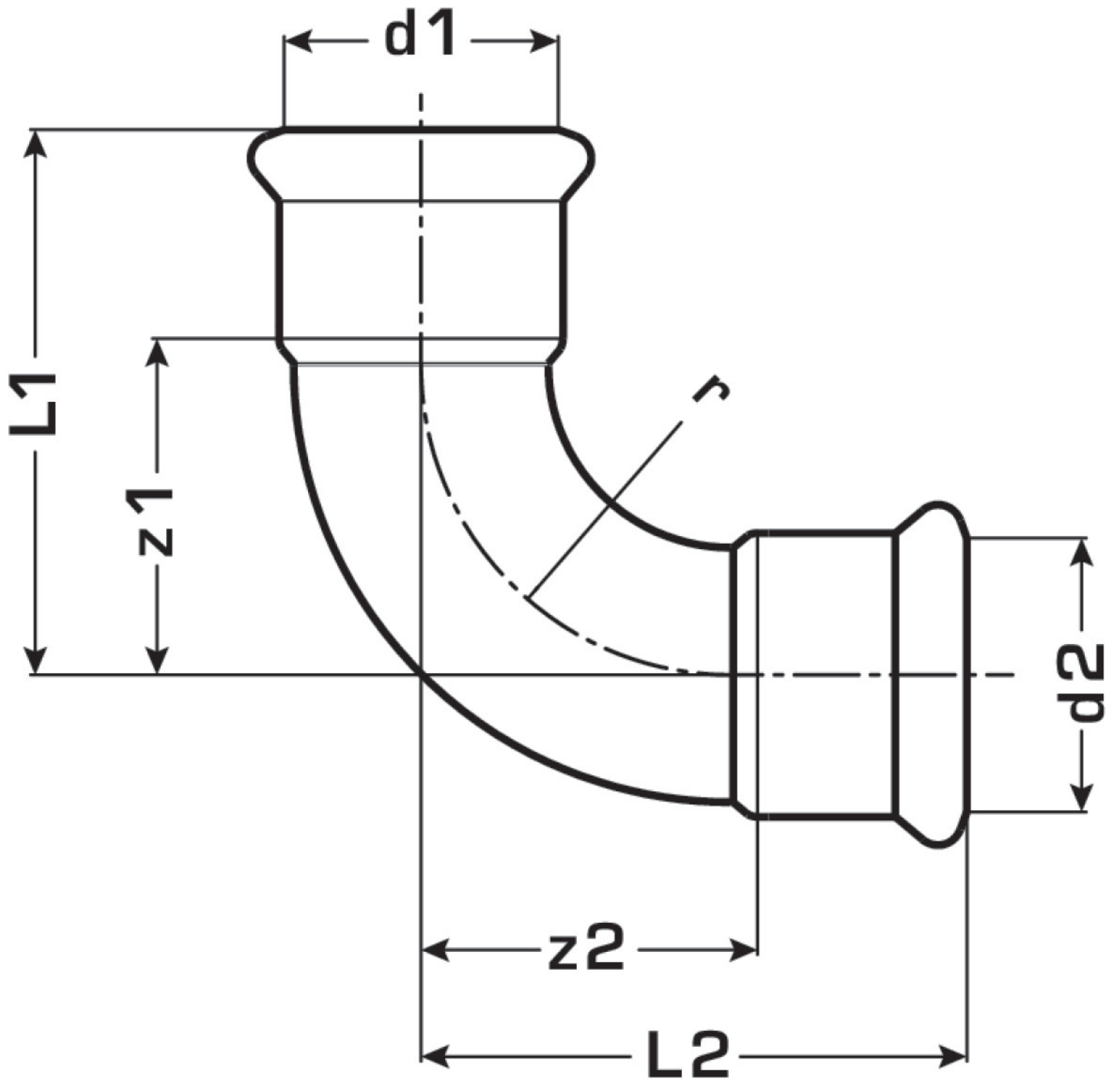

Art. No	label	d1 mm	d2 mm	L1 mm	L2 mm	z1 mm	z2 mm
54615HH0	54	54	54	105	105	70	70