

# STEEL FIX EDELSTAHL

NP486 STEELFIX stainless steel press-fit-adapter flange PN10/16 42-DN40 4-hole

53755G00

## Areas of application



Press-adapter flange, flat-sealing made of 1.4404 stainless steel, depending on the size with flat or grooved sealing surface, incl. EPDM sealing elements, d15-54 "leak before pressed"

Hole circle dimensioning conforming to DIN 2501-PN16

Press contour: M

## Approvals:



# Specifications

## Article information

port 1	Pressmuffe
port 2	Flansch
execution	1-part
design	gerade
press contour	M

## Technical properties

PN	PN 16
----	-------

## Product information

VPE1	1,00 KT1
weight	1,782 KGM
text	STEELFIX stainless steel press-fit-adapter flange PN10/16
INTRNR	73072980
material group	EDELSTAHL pressfittings
code	NP486

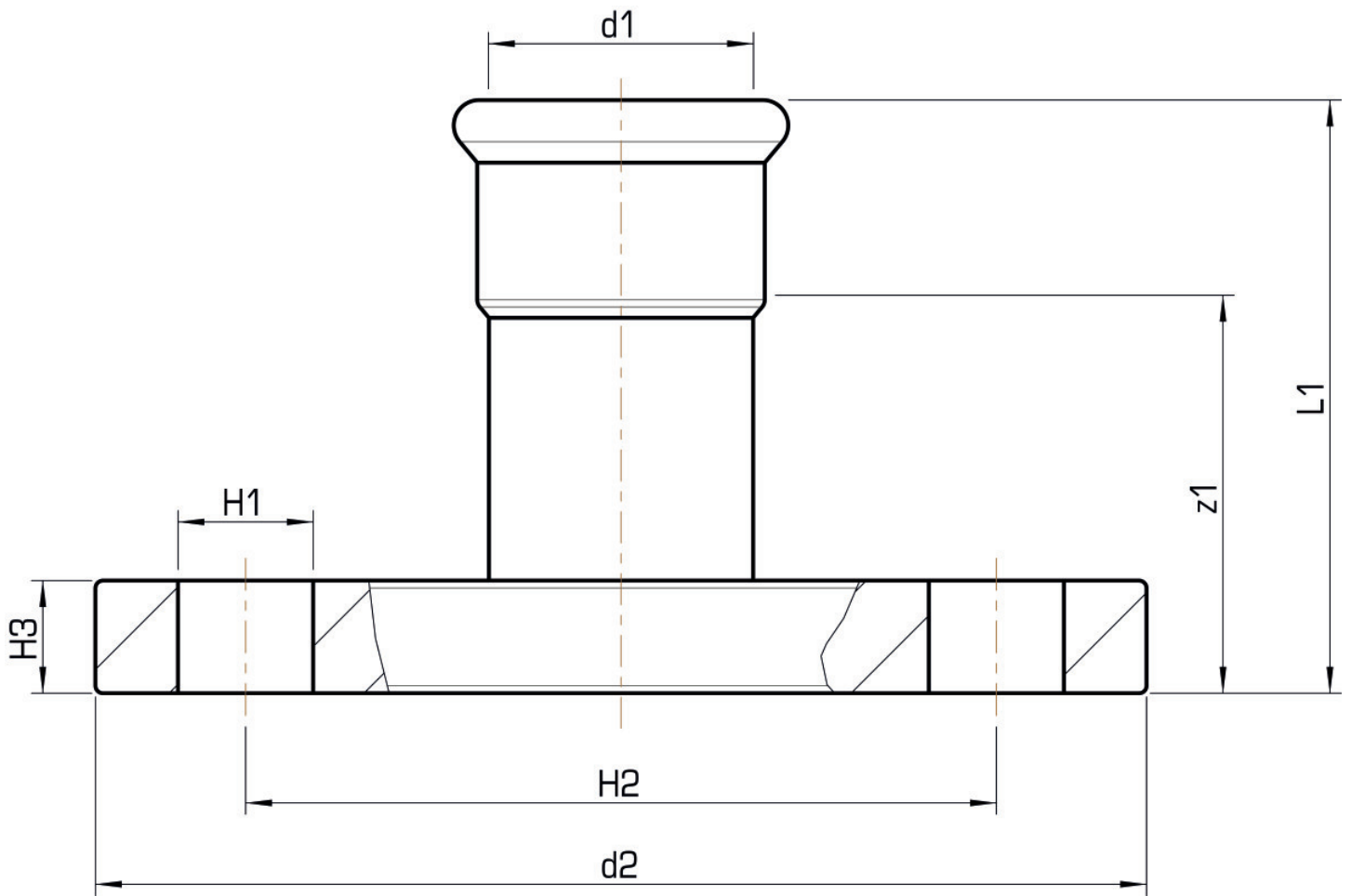

Art. No	label	d2 Zoll	d1 mm	L1 mm	z1 mm	pitch circle diameter mm
53755G00	42-DN40 4-hole	DN 40	42	91	61	110