

KETRIX

TRI35ST KETRIX reducer-tee - PN10 160/90/160

55510PKP

Areas of application

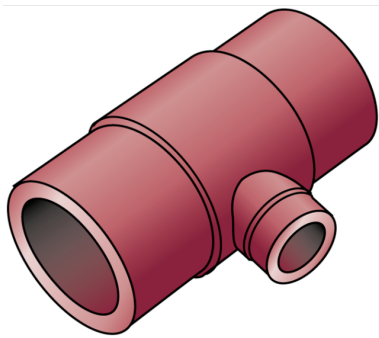

KETRIX butt weld fitting PN10, for connecting POB pipes to fittings made of the same material

Specifications

Article information

port 1	Pipe end
port 2	Pipe end
port 3	Plastic welding socket
execution	T-piece
angle	90 °

Technical properties

maximum working pressure at 20 ° C	10 bar
------------------------------------	--------

Product information

VPE1	1,00 SA1
weight	3,000 KGM
text	KETRIX reducer-tee - PN10
INTRNR	39174000
main material group	KETRIX
material group	KETRIX plastic fittings
code	TRI35ST

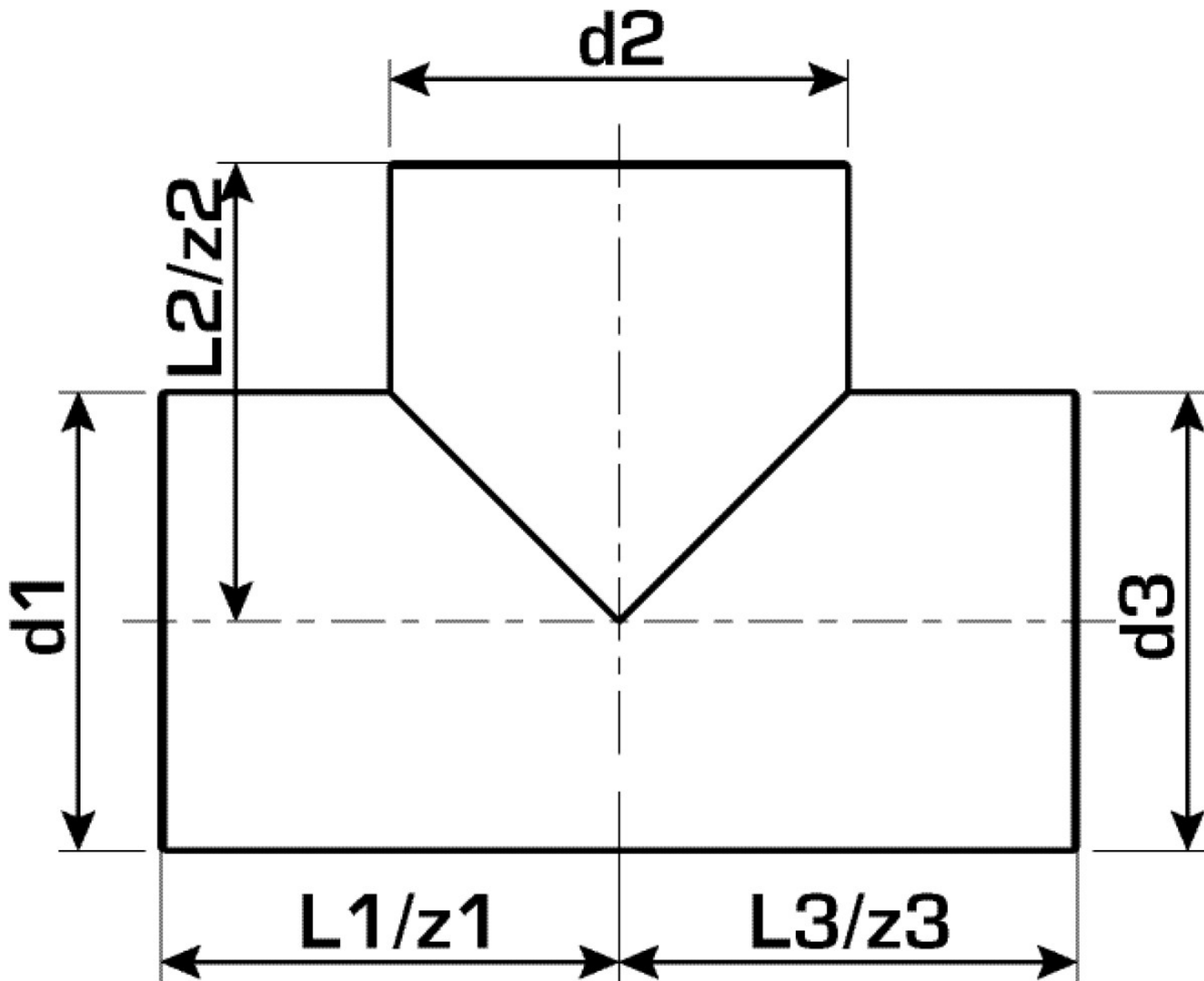

Art. No	label	d1 mm	d2 mm	d3 mm	L1 mm	L2 mm	L3 mm	z1 mm	z2 mm	z3 mm
55510PKF	160/90/16	160	90	160	175	182	175	175	182	175