

KELOX

KMP485K KELOX-PROTEC connection set 2.5cm 16x1/2" 15cm

73292B02

Areas of application

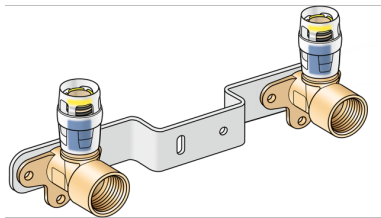

With KMP480 plug-in wall bracket fittings with female thread, made of dezincification-resistant brass (DZR), incl. push-on sleeve made of transparent polyamide, O-rings, withdrawal barriers and a protector ring as an insertion locking device

Overall height:

DO NOT screw in any threaded pipes and cast iron fittings!

Approvals:



Specifications

Product information

VPE1	10,00 KT1
weight	0,703 KGM
text	KELOX-PROTEC connection set 2.5cm
INTRNR	74122000
main material group	KELOX
material group	KELOX-PROtec pushfittings
code	KMP485K

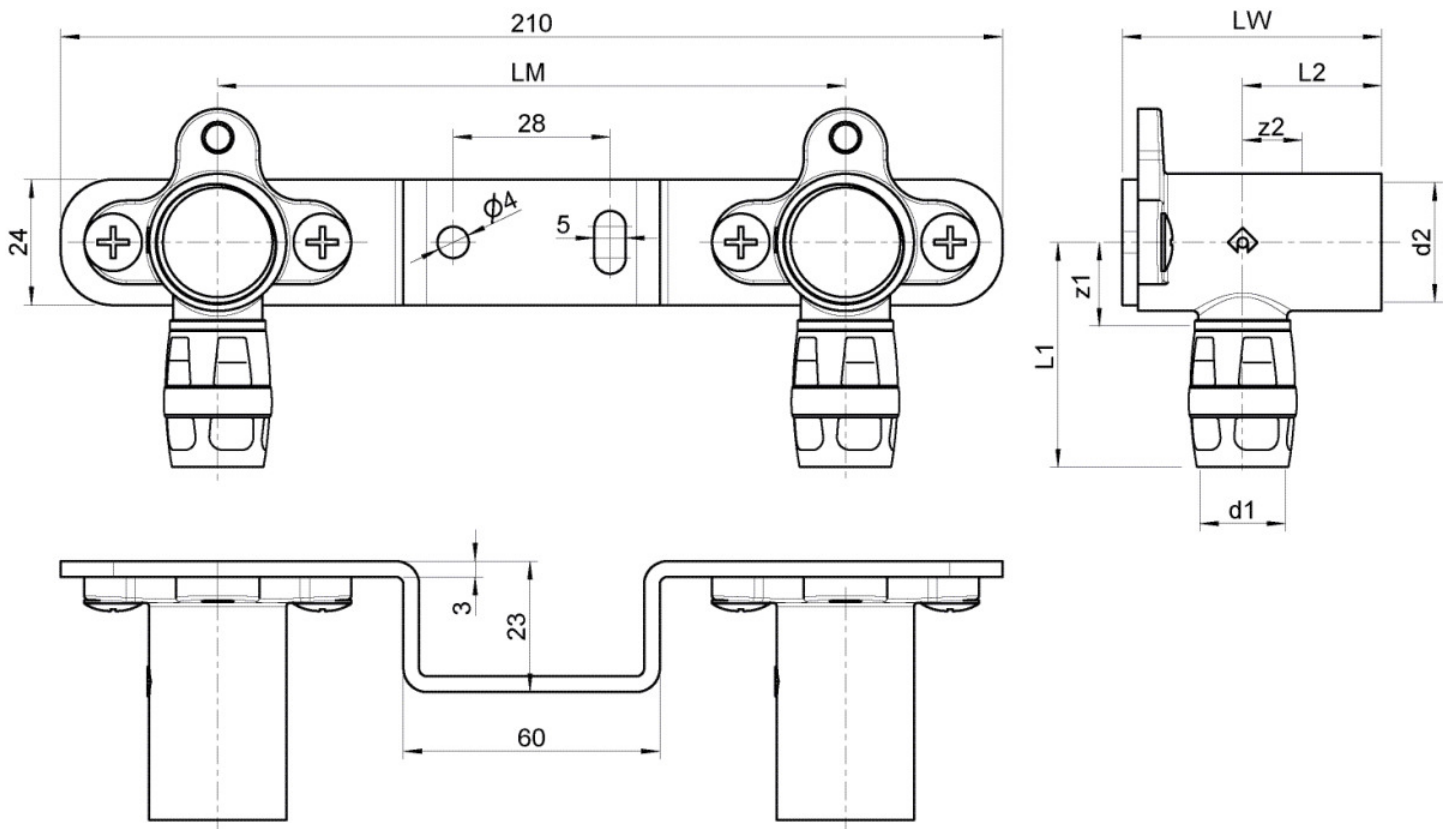

Art. No	label	d1 mm
73292B02	16x1/2" 15cm	16



KE KELIT GmbH

A 4020 Linz, Ignaz-Mayer-Straße 17, Austria, Europe

PHONE +43 (0) 50 779 **E-MAIL** office@kekelit.com

www.kekelit.com