

# KELOX

## KMU432 KELOX-ULTRAX radiator tee 16x16/330

71153BB2

### Areas of application

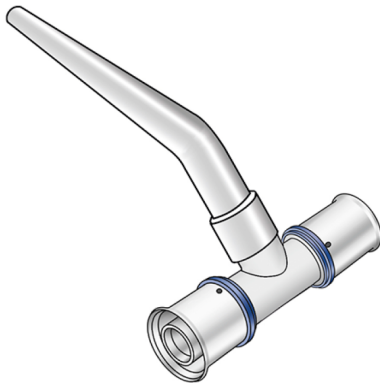

?Radiator connecting pipe made of semi-rigid nickel-plated d15 copper with press-fit adapter tee made from non-porous metallised brass, incl. support sleeves with O-rings and stainless steel press-fit sleeves; "leak before pressed"

ATTENTION: Follow the installation instructions of the screw fitting manufacturer and if necessary use support sleeves for copper connections!

## Approvals:



# Specifications

## Article information

port 1	Pressing socket
port 2	Zapfen/Rohrende
port 3	Pressing socket
execution	Tee piece
press contour	U

## Technical properties

maximum working pressure at 20 ° C	10 bar
------------------------------------	--------

## Product information

VPE1	1,00 SA1
VPE2	30,00 KT1
weight	0,104 KGM
text	KELOX-ULTRAX radiator tee
INTRNR	74122000
main material group	KELOX
material group	KELOX-ULTRAX metal fittings
code	KMU432

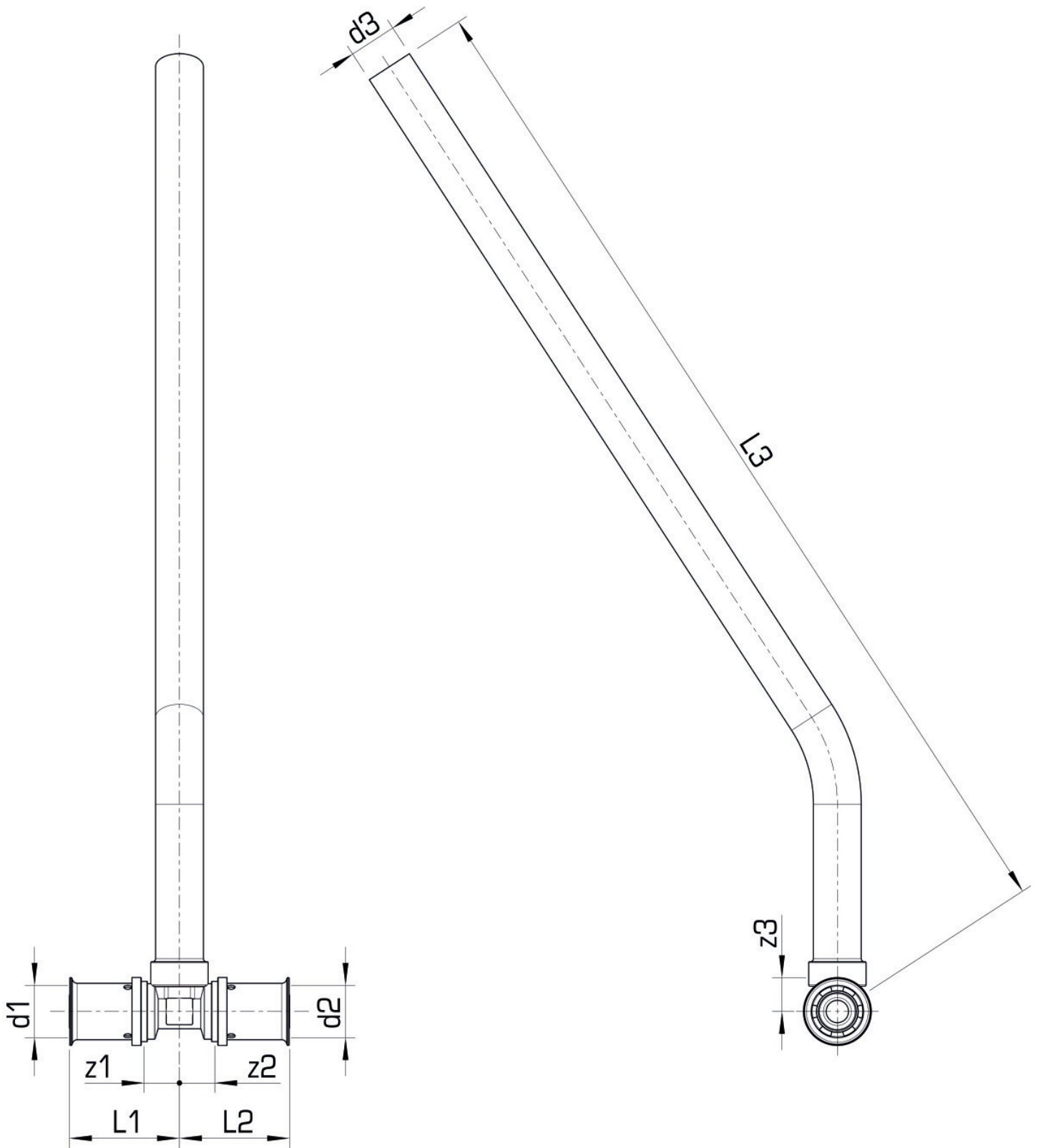

Art. No	label	d1 mm	d2 mm	d3 mm	L1 mm	L2 mm	L3 mm	z1 mm	z2 mm	z3 mm
71153BB2	16x16/33C	16	15	15	35	330	35	12,5	9	12,5



**KE KELIT GmbH**

A 4020 Linz, Ignaz-Mayer-Straße 17, Austria, Europe

**PHONE** +43 (0) 50 779 **E-MAIL** office@kekelit.com

www.kekelit.com