

# KELOX

KMU456K KELOX-ULTRAX union 90° with female thread and wedge seal 16x1/2"

71207B02

## Areas of application

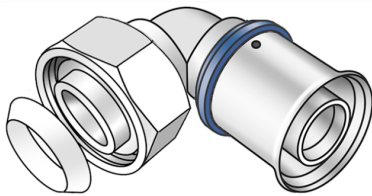

Press-fit elbow union 90° with female thread for connecting to fittings or threaded nipples made of non-porous metallised brass (CW724R), incl. support sleeves with O rings and stainless steel press-fit sleeves, "leak before pressed", incl. wedge seal

## Approvals:



# Specifications

## Article information

port 2	Überwurfmutter
execution	1-part
design	Winkel
angle	90 °
press contour	U

## Technical properties

maximum working pressure at 20 ° C	10 bar
------------------------------------	--------

## Product information

VPE1	10,00 SA1
VPE2	120,00 KT1
weight	0,102 KGM
text	KELOX-ULTRAX union 90° with female thread and wedge seal
INTRNR	74122000
main material group	KELOX
material group	KELOX-ULTRAX metal fittings
code	KMU456K

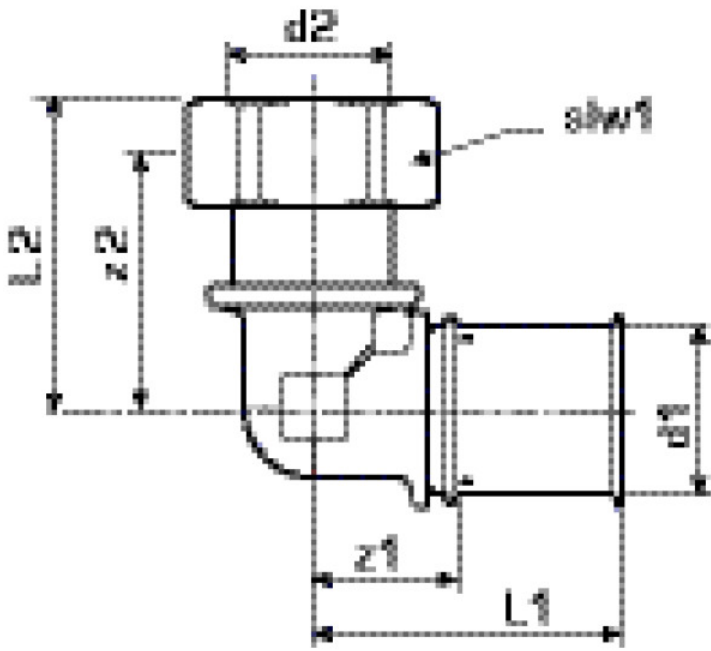

Art. No	label	d2	d1 mm	L1 mm	L2 mm	z1 mm	z2 mm	slw1 mm
71207B02	16x1/2"	1/2" (15)	16	38	39	16	2	24