

KELOX

KMW447 KELOX-ULTRAX-W tee with branch female 32x1"

71440F05

Areas of application

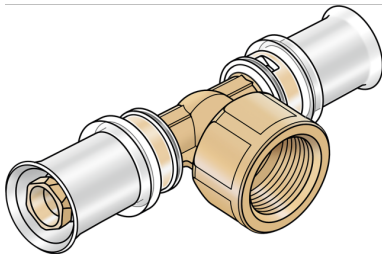

?Zeta value-optimised press-fit tee with female thread branch, made from dezincification-resistant, (DZR) brass, including support sleeves with O-rings and stainless steel press-fit sleeves "leak before pressed", audible leakage signal at air-pressure testing
DO NOT screw in threaded pipes and cast iron fittings!

Approvals:



Specifications

Article information

port 1	Pressmuffe
port 2	Innengewinde zylindrisch (BSPP)
port 3	Pressmuffe
execution	T-Stück
press contour	U

Technical properties

maximum working pressure at 20 ° C	16 bar
------------------------------------	--------

Product information

VPE1	5,00 SA1
VPE2	20,00 KT1
VPE3	1200,00 PAL
weight	0,327 KGM
text	KELOX-ULTRAX-W tee with branch female
INTRNR	74122000
main material group	KELOX
code	KMW447

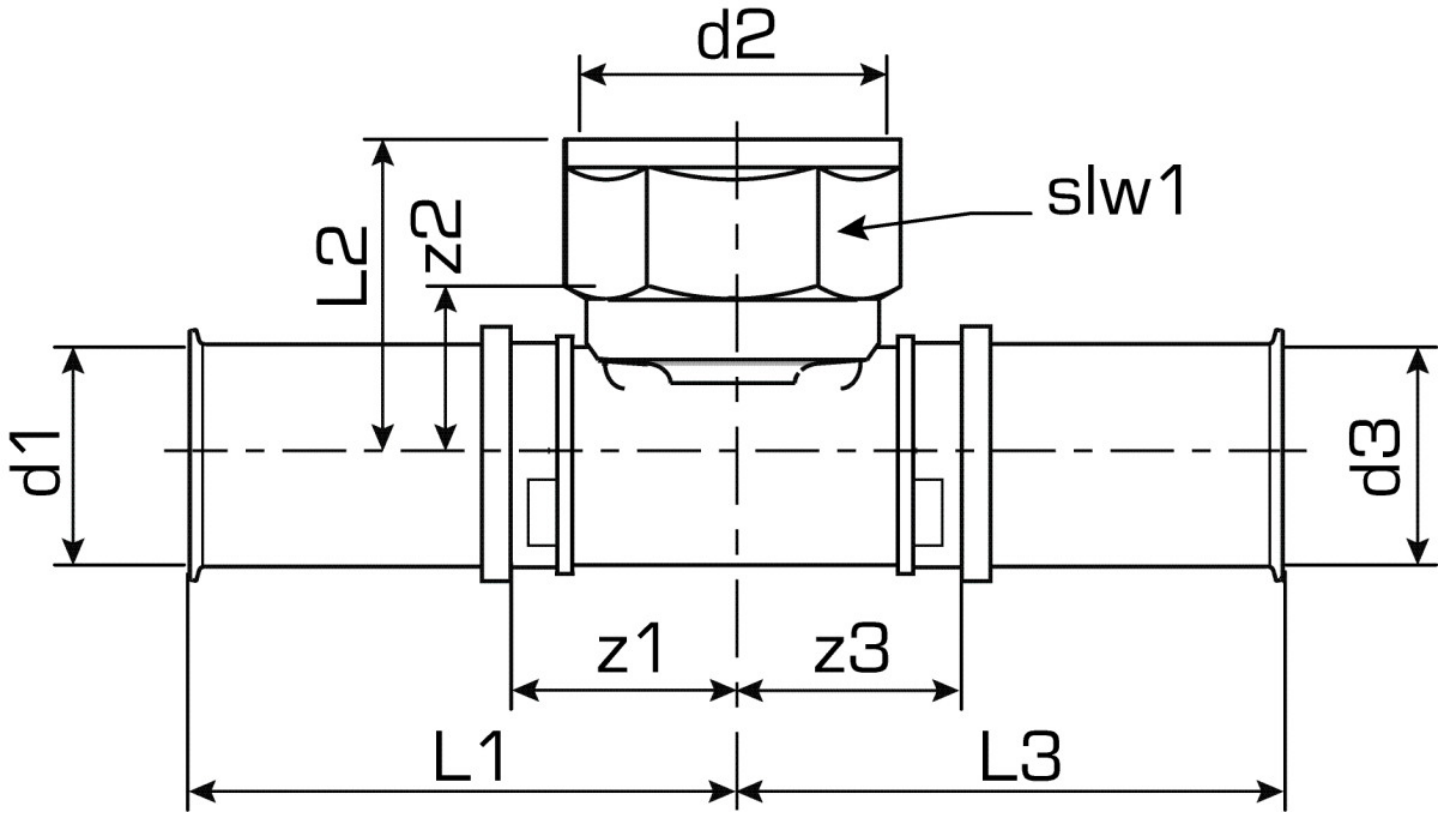

Art. No	label	d2	d1 mm	d3 mm	L1 mm	L2 mm	L3 mm	z1 mm	z2 mm	z3 mm	slw1 mm
71440F0	32x1"	1"	32	32	60	38,5	53	22	18	23	42