

KELOX

KWW475 ?KELOX-WINDOW-W fitting connection tee with female thread 16x1/2"

72452B2B

Areas of application

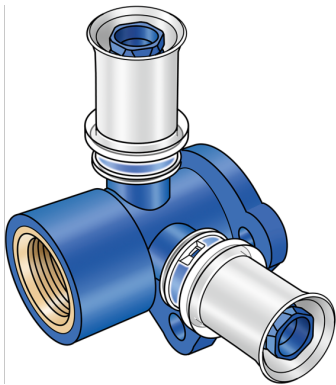

?Zeta value-optimised press-fit fitting connection tee with female thread, made from PPSU, including support sleeves with O-rings and stainless steel press-fit sleeves "leak before pressed", audible leakage signal at air-pressure testing

Overall height:

1/2" - 50mm

DO NOT screw in threaded pipes and cast iron fittings!

DO NOT use liquid sealants!

Approvals:



Specifications

Article information

port 1 Pressmuffe

press contour U

Technical properties

maximum working pressure at 20 ° C 10 bar

Product information

VPE1 10,00 SA1

VPE2 20,00 KT1

VPE3 1440,00 PAL

weight 0,093 KGM

text ?KELOX-WINDOX-W fitting connection tee with female thread

INTRNR 74122000

main material group KELOX

code KWW475

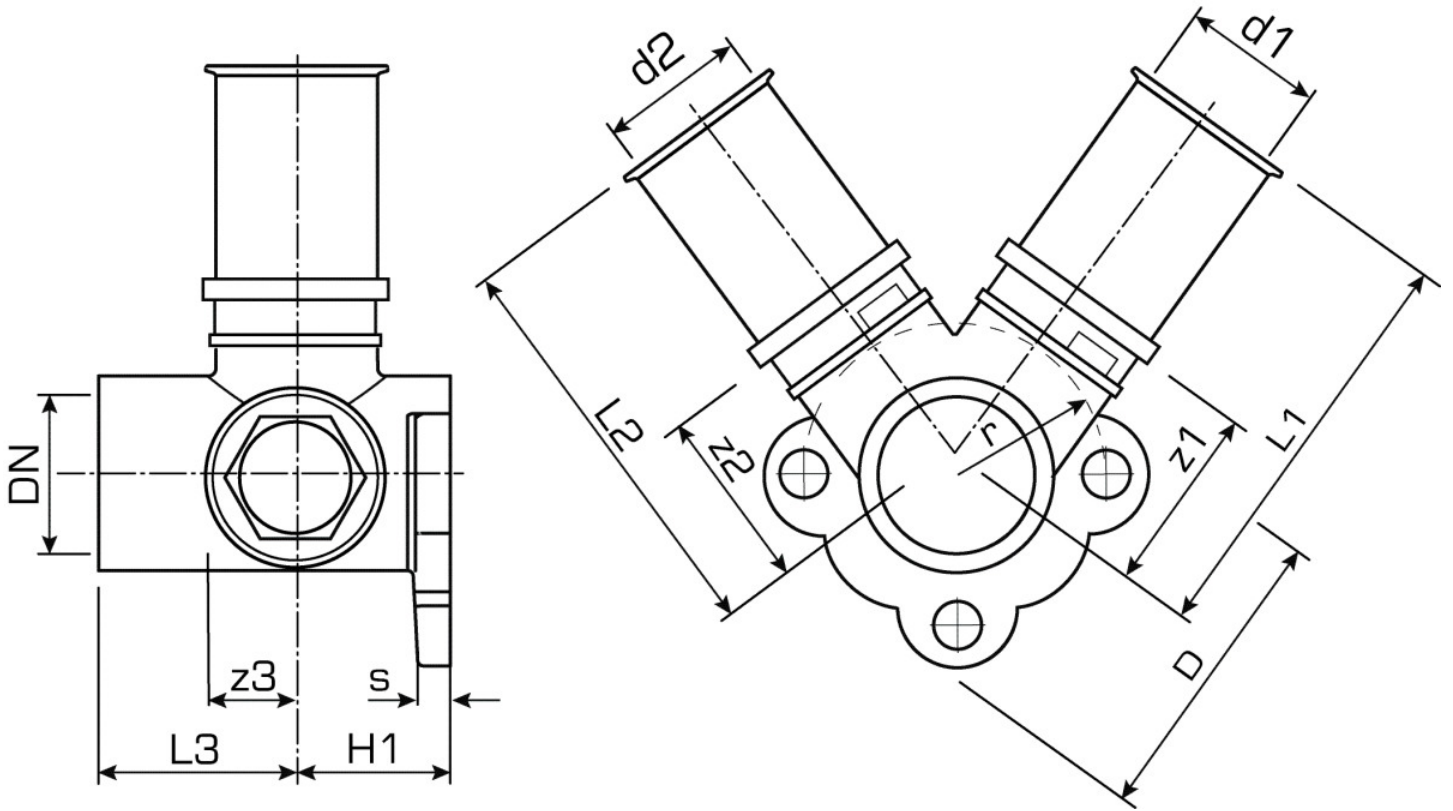

Art. No	label	d1 mm	L1 mm	L2 mm	L3 mm	z1 mm	z2 mm	z3 mm
72452B2B	16x1/2"	16	55	55	28,5	29	29	11