

STEELOX

SMX440Z ?STEELOX zeta tee 20/20/20

57111DDD

Areas of application

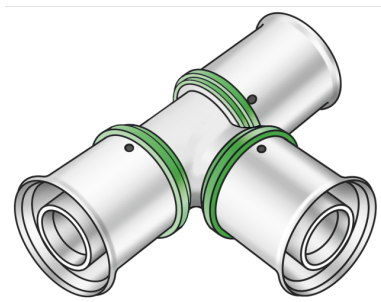

?Zeta value-optimised press-fit tee, equal or reduced, made of non-porous metallised dezincification-resistant (DZR) brass, incl. support sleeves with O-rings and stainless steel pressing sleeves, "leak before pressed"

Approvals:



KE KELIT GmbH

A 4020 Linz, Ignaz-Mayer-Straße 17, Austria, Europe

PHONE +43 (0) 50 779 E-MAIL office@kekelit.com

www.kekelit.com

Specifications

Article information

port 1	Pressing socket
port 2	Pressing socket
port 3	Pressing socket
execution	Tee piece
angle	90 °
press contour	SX

Technical properties

maximum working pressure at 20 ° C	10 bar
------------------------------------	--------

Product information

VPE1	10,00 SA1
VPE2	100,00 KT1
weight	0,136 KGM
text	?STEELOX zeta tee
INTRNR	74122000
code	SMX440Z

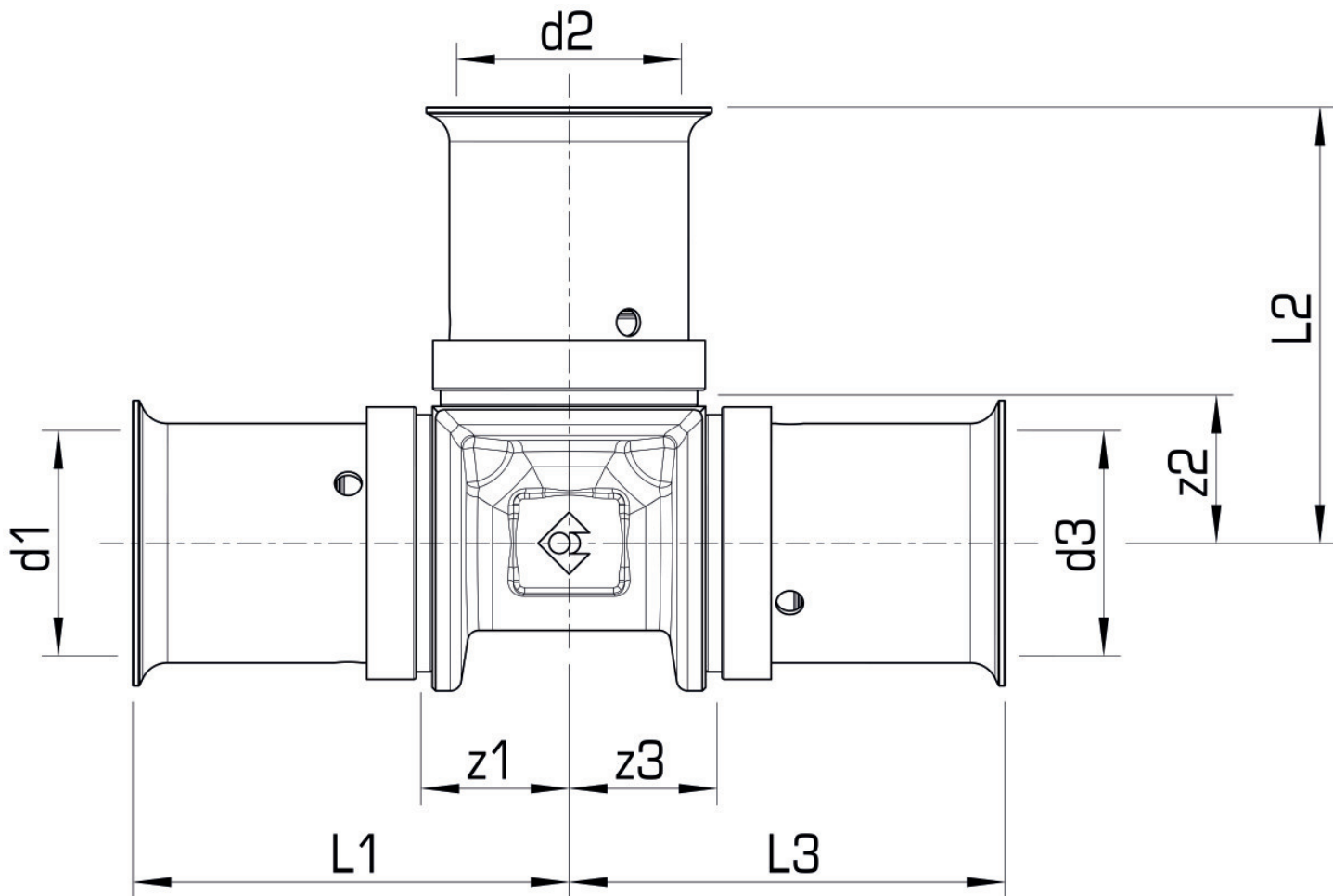

Art. No	label	d1 mm	d2 mm	d3 mm	L1 mm	L2 mm	L3 mm	z1 mm	z2 mm	z3 mm
57111DDI	20/20/20	20	20	20	40	40	40	14,5	14,5	14,5