

STEELOX

SMX447 ?STEELOX tee with female thread branch 16x1/2"

57240B02

Areas of application

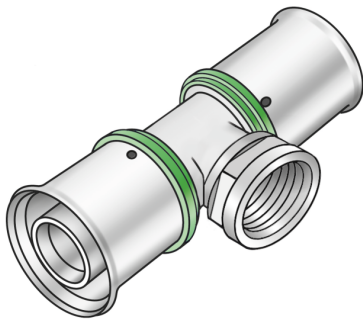

?Press-fit tee with female thread branch, made of non-porous metallised dezincification-resistant brass (DZR), incl. support sleeves with O-rings and stainless steel pressing sleeves, "leak before pressed"

DO NOT join threaded pipe or malleable iron fittings!

Approvals:



Specifications

Article information

port 1	Pressing socket
port 2	Female thread
port 3	Pressing socket
execution	Tee piece
angle	90 °
press contour	SX

Technical properties

maximum working pressure at 20 ° C	10 bar
------------------------------------	--------

Product information

VPE1	10,00 SA1
VPE2	100,00 KT1
weight	0,110 KGM
text	?STEELOX tee with female thread branch
INTRNR	74122000
code	SMX447

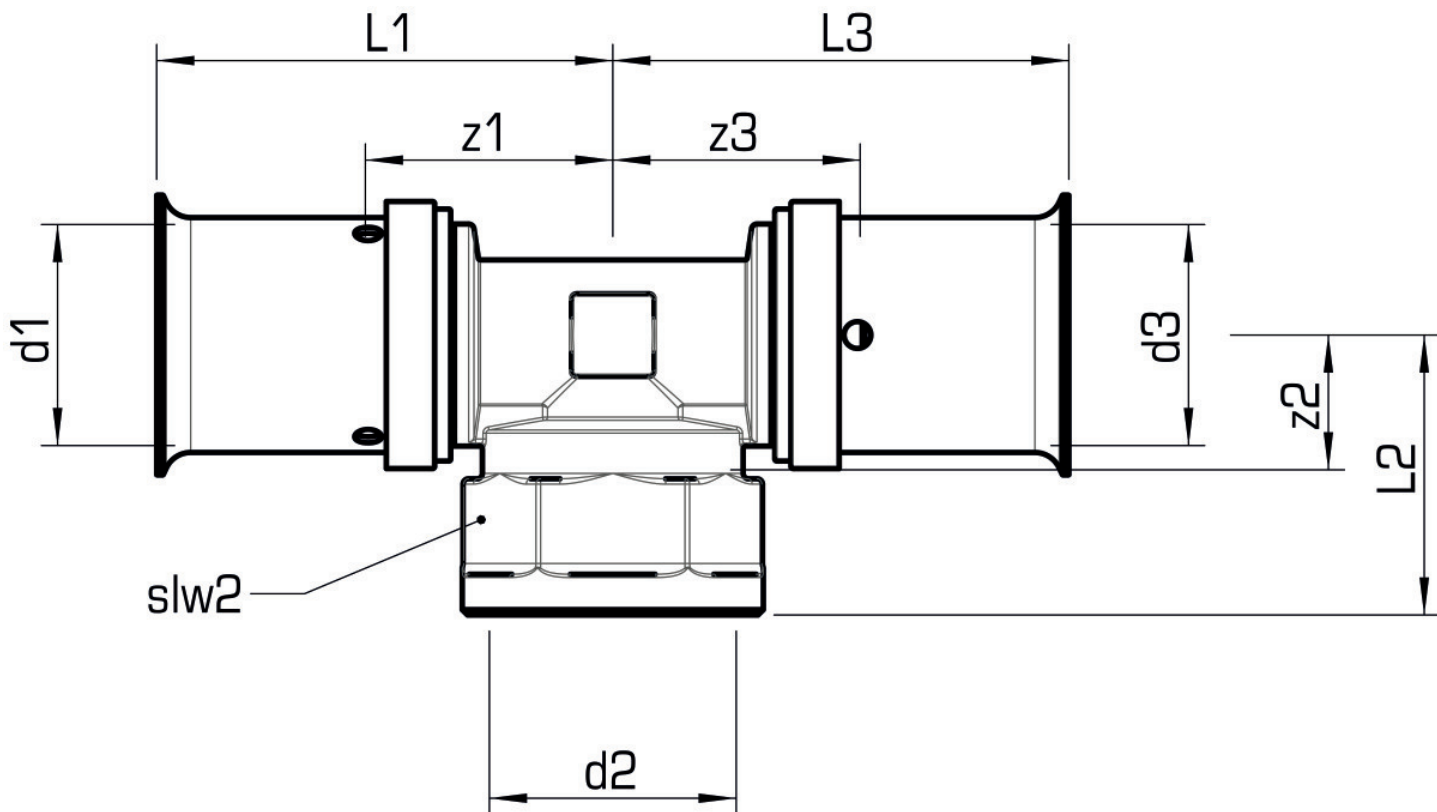

Art. No	label	d2 Inches	d1 mm	d3 mm	L1 mm	L2 mm	L3 mm	z1 mm	z2 mm	z3 mm	slw1 mm
57240B0	16x1/2"	1/2" (15)	16	16	40	27	40	17	14	17	24