

STEEL FIX C-STAHL

CF100 STEELFIX carbon steel pipe 54x1.5

54001H00

Areas of application

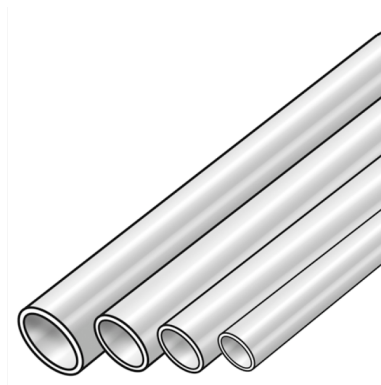

?Thin-walled, longitudinally welded stainless steel pipes according to EN 10305-3 with particularly low carbon content and with the outside protected by a thermally applied zinc layer and a passivating/chromium layer

Application area: Closed heating circuits, closed cooling circuits (observe corrosion protection measures!)

Operating temperature: - 35°C to 120°C - tmax 150°C/16 bar - briefly

Rod length: 6m

Specifications

Technical properties

pipe weight 1,99 kg/m

pipe contents 2,043 l/m

Product information

VPE1 90,00 BND

L 6 m

weight 2,100 KGM

text STEELFIX carbon steel pipe

INTRNR 73065080

main material group STEELFIX

material group C-STAHl pipes

code CF100

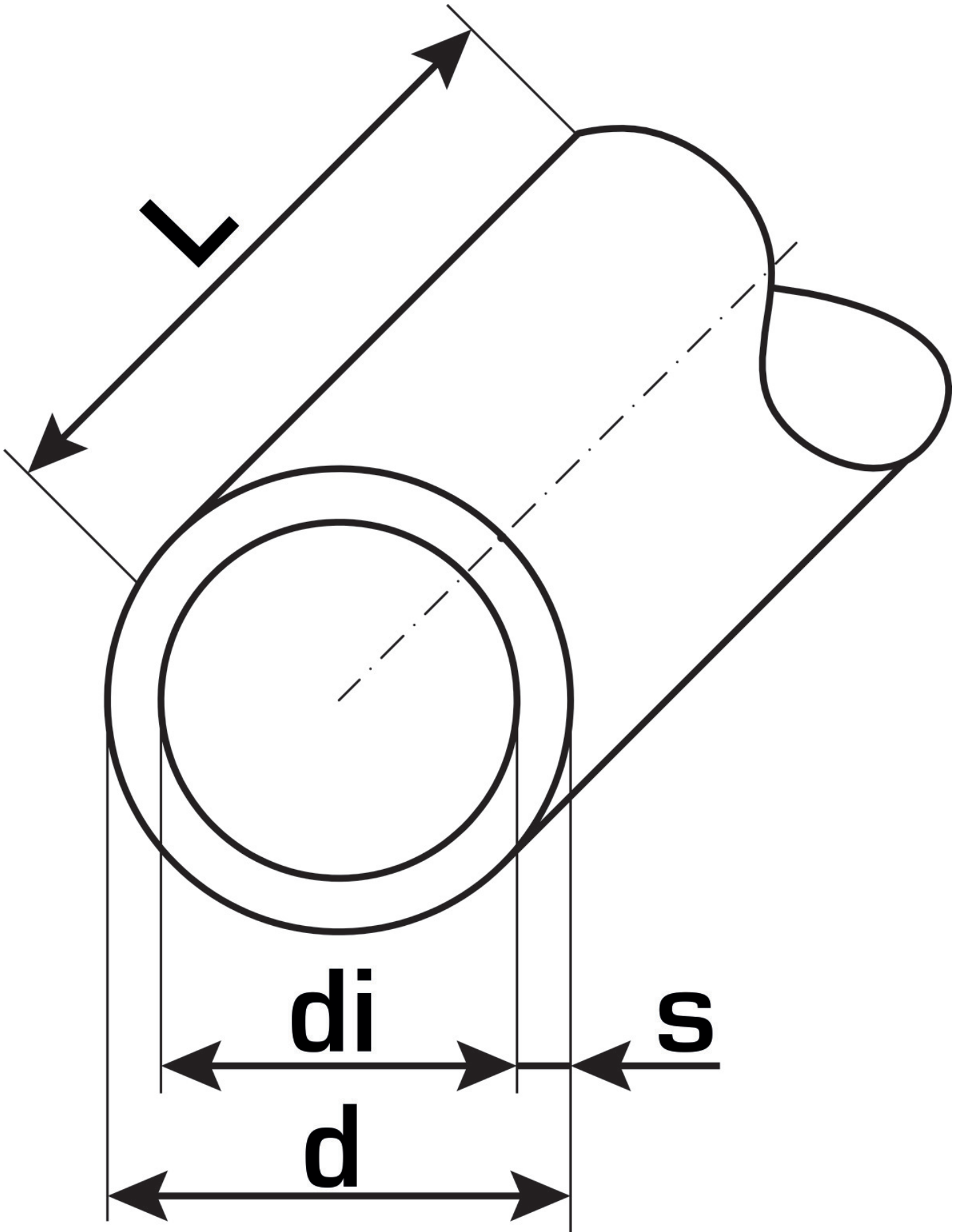

Art. No	label	d	d1 mm	pipe contents l/m	s mm
54001H00	54x1.5	51	54	2,043	1,5



KE KELIT GmbH

A 4020 Linz, Ignaz-Mayer-Straße 17, Austria, Europe

PHONE +43 (0) 50 779 **E-MAIL** office@kekelit.com

www.kekelit.com