

# STEEL FIX C-STAHl

CP486 C-Steel press-adaptor flange PN10/16 67-DN65 4-hole

54755I00

## Areas of application

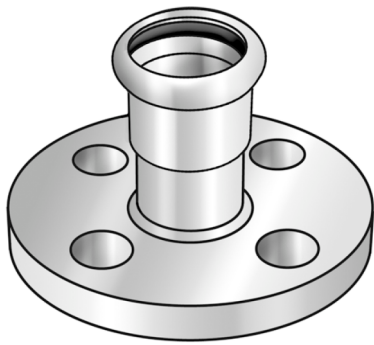

Press-fit adaptor flange, flat-sealing made of carbon steel coated with a zinc layer, incl. EPDM sealing components, d15-54 "leak before pressed"

hole circle dimensioning conforming to DIN 2501-PN16

Press contour: M

# Specifications

## Article information

port 1	Pressmuffe
port 2	Flansch
execution	1-teilig
design	gerade
press contour	M

## Technical properties

PN	PN 16
----	-------

## Product information

VPE1	1 STK
VPE2	2 KT1
weight	3,295 KGM
text	C-Steel press-adaptor flange PN10/16
INTRNR	73079980
main material group	STEELFIX
material group	C-STAHL pressfittings
code	CP486

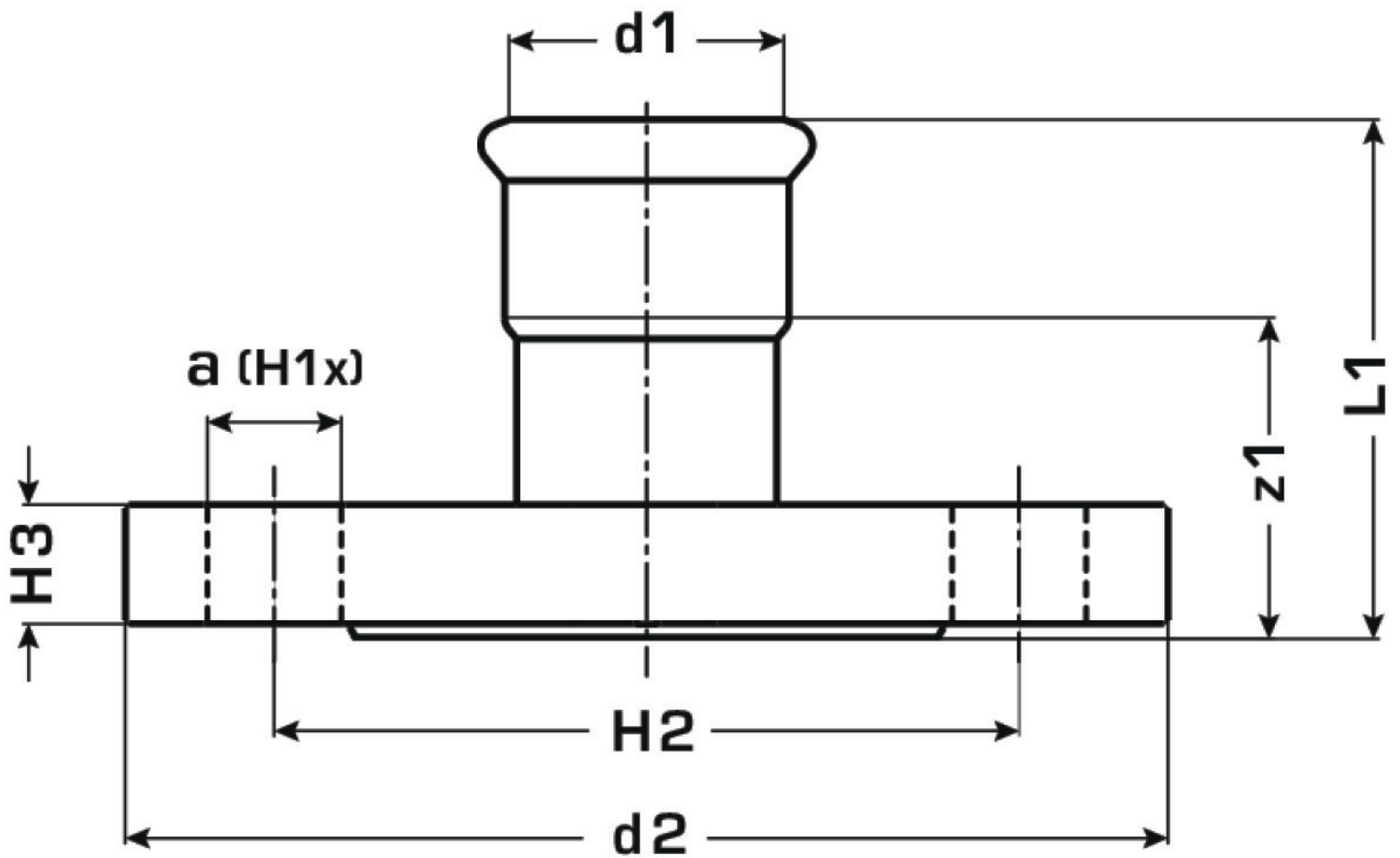

Art. No	label	d2	d1 mm	L1 mm	z1 mm	number of holes	pitch circle diameter mm
54755100	67-DN65 4-hole	DN65	66.7	71	21	4	145