

STEEL FIX EDELSTAHL

NP486 STEELFIX stainless steel press-fit-adapter flange PN10/16 76-DN65 4-hole

53755J00

Areas of application

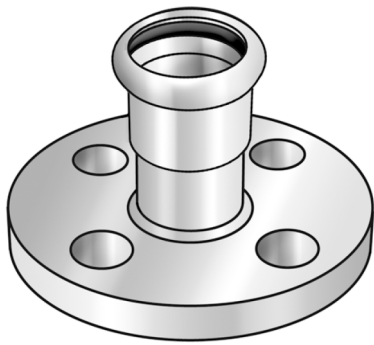

Press-adapter flange, flat-sealing made of 1.4404 stainless steel, depending on the size with flat or grooved sealing surface, incl. EPDM sealing elements, d15-54 "leak before pressed"

Hole circle dimensioning conforming to DIN 2501-PN16

Press contour: M

Approvals:



Specifications

Article information

| | |
|---------------|------------|
| port 1 | Pressmuffe |
| port 2 | Flansch |
| execution | 1-part |
| design | gerade |
| press contour | M |

Technical properties

| | |
|----|-------|
| PN | PN 16 |
|----|-------|

Product information

| | |
|----------------|---|
| VPE1 | 1,00 KT1 |
| weight | 3,350 KGM |
| text | STEELFIX stainless steel press-fit-adapter flange PN10/16 |
| INTRNR | 73072980 |
| material group | EDELSTAHL pressfittings |
| code | NP486 |

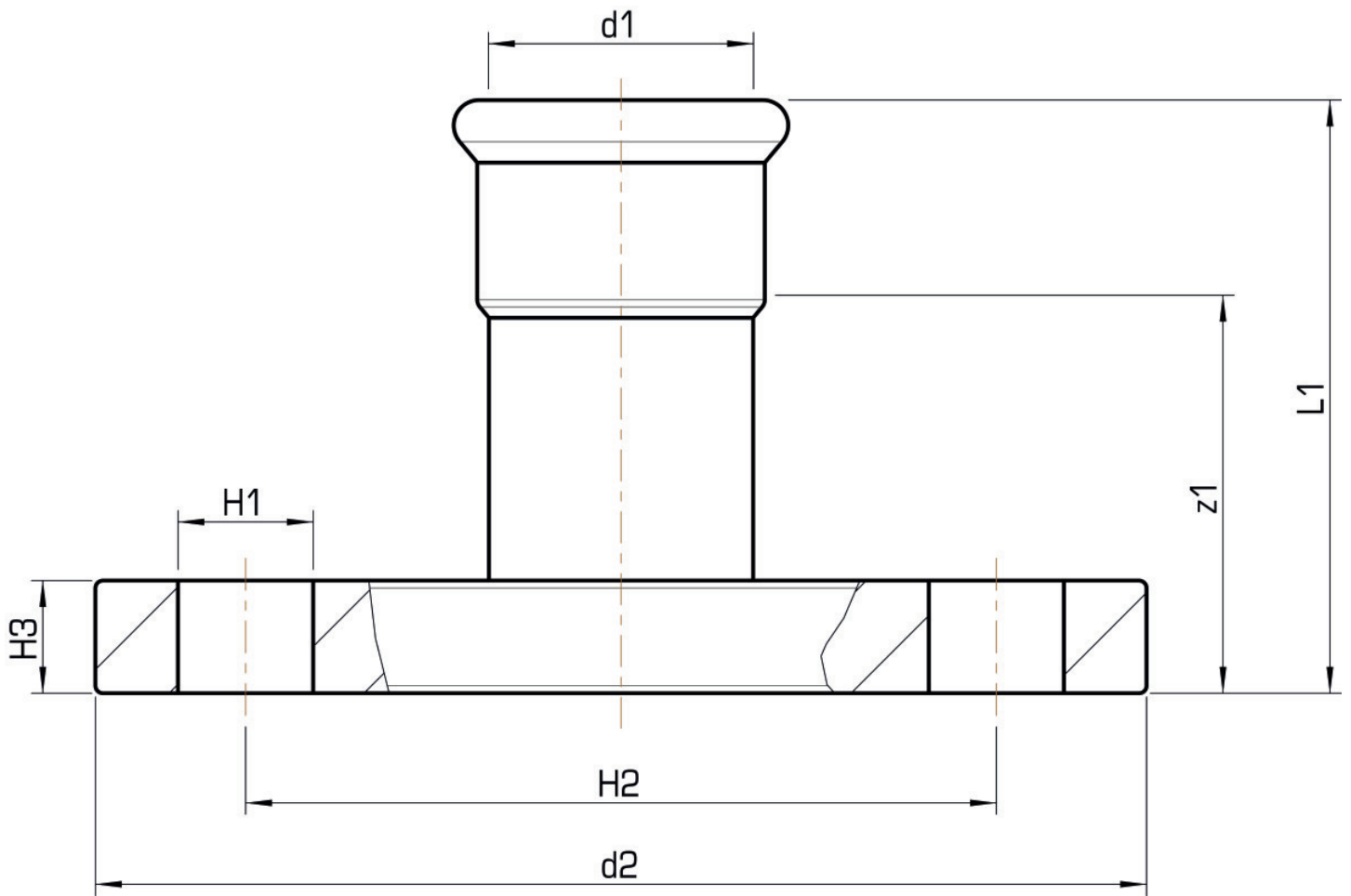

| Art. No | label | d2 Zoll | d1 mm | L1 mm | z1 mm | pitch circle diameter mm |
|----------|----------------|---------|-------|-------|-------|--------------------------|
| 53755J00 | 76-DN65 4-hole | DN 65 | 76,1 | 126 | 71 | 145 |