

KMU483 KELOX-ULTRAX wall duct 90° female 16x1/2"

71256B02

Areas of application

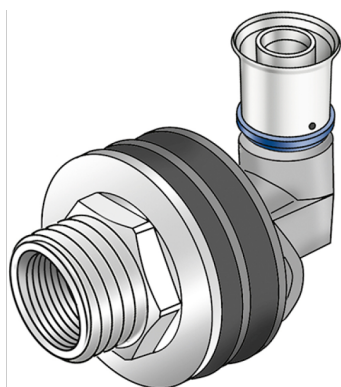

Press fitting wall duct with female thread for dry construction, incl. locknut and two sound-insulating sealing washers, made of non-porous metallised brass; including support sleeves with O-rings and steel or stainless steel press-fit sleeves; "leak before pressed"

DO NOT screw in any threaded pipes and cast iron fittings!

Approvals:



Specifications

Article information

port 1	Pressing socket
port 2	Female thread cylindrical BSPT-Rp (ISO 7-1)
execution	2-part
design	Knee
angle	90 °
press contour	U

Technical properties

maximum working pressure at 20 ° C	10
------------------------------------	----

Product information

VPE1	10,00 SA1
VPE2	60,00 KT1
weight	0,275 KGM
text	KELOX-ULTRAX wall duct 90° female
INTRNR	74122000
main material group	KELOX
material group	KELOX-ULTRAX metal fittings
code	KMU483

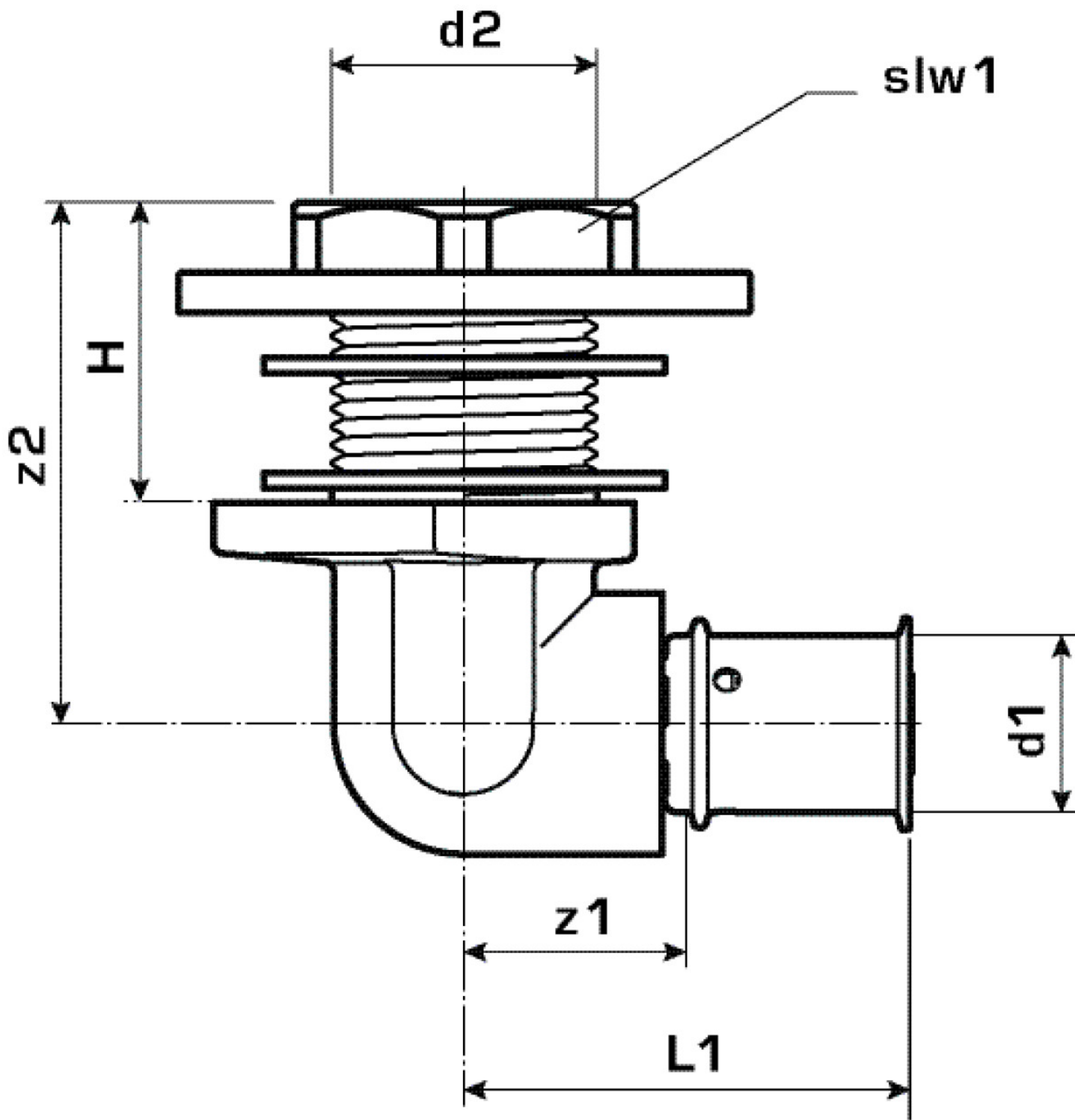

Art. No	label	d2 Inches	d1 mm	L1 mm	z1 mm	z2 mm	slw1 mm
71256B02	16x1/2"	1/2" (15)	16	44	23	53	34