

# STEEL FIX EDELSTAHL

NP478 Stainless steel press-axial expansion joint  
- socket end 22

53754DD0

## Areas of application

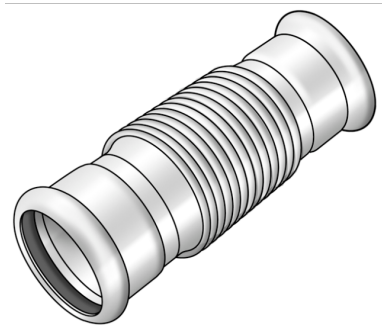

Press-axial expansion joint straight made of stainless steel 1.4404 with two socket ends, to balance out the thermal expansion of piping systems

NOT deadroom-free!

Position 0 at 20°C

Compensation:

d18: 16mm

d22: 20mm

d28: 22mm

d35: 24mm

d42: 24mm



KE KELIT GmbH

A 4020 Linz, Ignaz-Mayer-Straße 17, Austria, Europe

PHONE +43 (0) 50 779 E-MAIL [office@kekelit.com](mailto:office@kekelit.com)

[www.kekelit.com](http://www.kekelit.com)

d54: 30mm

Press contour: M

## Approvals:



# Specifications

## Article information

**port 1** Pressmuffe

**execution** Axial

## Product information

**VPE1** 5 SA1

**VPE2** 30 KT1

**weight** 0,13 KGM

**text** Stainless steel press-axial expansion joint - socket end

**INTRNR** 73072980

**main material group** STEELFIX

**material group** EDELSTAHL pressfittings

**code** NP478

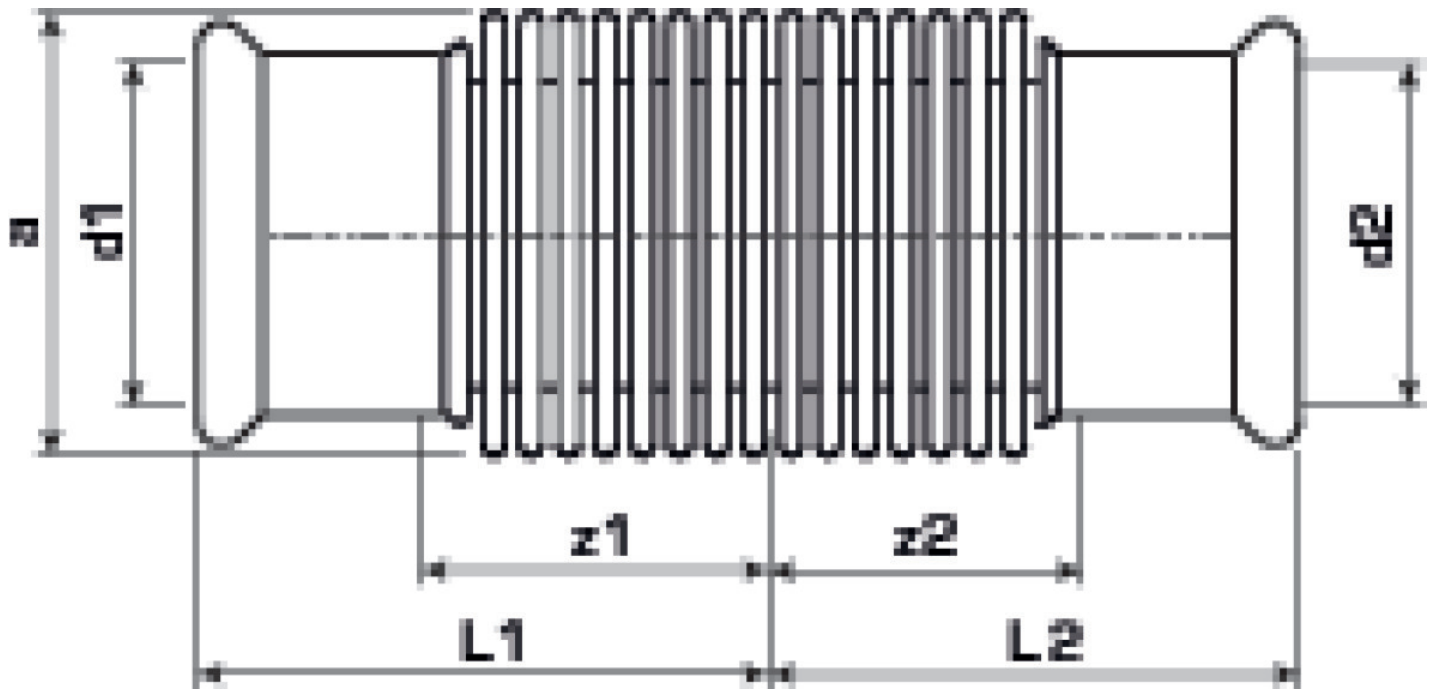

Art. No	label	d1 mm	L1 mm	L2 mm	Z1 mm	Z2 mm
53754DD0	22	22	60	60	39	39