

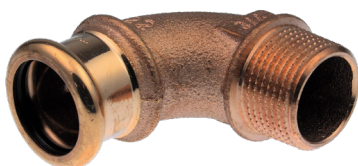

COF460 Kupfer Press-Übergangswinkel 90° mit AG

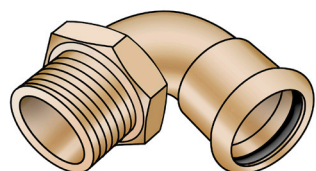

Symbolgrafik

Produktbeschreibung:

Press-Übergangswinkel 90° mit Außengewinde nach EN 10226-1 aus Rotguss, inkl. EPDM-Dichtelemente, „unverpresst undicht“

Presskontur: M

Produkteigenschaften:

ÖVGW	W 1.741	Material	Rotguss
Verbindung 1	Pressmuffe	Verbindung 2	Außengewinde Gas konisch (BSPT)
Press-Kontur	M	Dichtung	EPDM

Erweiterte Produkteigenschaften:

Art.-Nr.	Bezeichnung	Gewicht	VPE1	VPE2	Mengeneinheit
52712B02	15x1/2"	0,085 KGM	10	50	STK
52712C02	18x1/2"	0,098 KGM	5	25	STK
52712D04	22x3/4"	0,145 KGM	5	25	STK
52712E05	28x1"	0,226 KGM	5	25	STK
52712F06	35x5/4"	0,217 KGM	5	20	STK
52712G07	42x6/4"	0,444 KGM	1	15	STK
52712H09	54x2"	0,596 KGM	1	10	STK





COF460 Kupfer Press-Übergangswinkel 90° mit AG

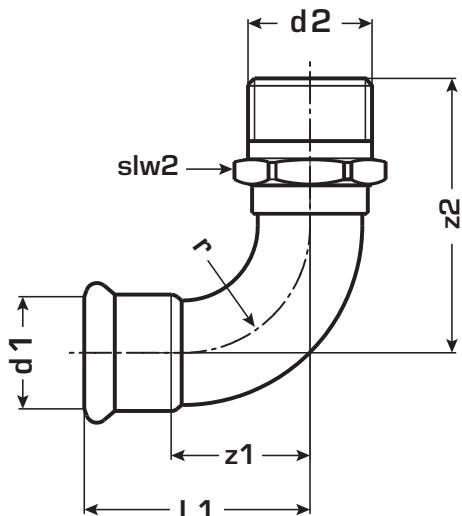

Art.-Nr.	Bezeichnung	d1 mm	z1 mm	z2 mm	L1 mm	d2 Zoll	slw2 mm
52712B02	15x1/2"	15	19	34	38	1/2 Zoll (15)	21
52712C02	18x1/2"	18	15	37	42	1/2 Zoll (15)	21
52712D04	22x3/4"	22	28	43	47	3/4 Zoll (20)	29
52712E05	28x1"	28	36	53	58	1 Zoll (25)	38
52712F06	35x5/4"	35	30	47	55	1 1/4 Zoll (32)	46
52712G07	42x6/4"	42	32	51	62	1 1/2 Zoll (40)	58
52712H09	54x2"	54	35	63	70	2 Zoll (50)	69

