

# KETRIX

## TRI43 KETRIX saddle fitting with female thread 40-50x3/4"

55213H04

### Areas of application

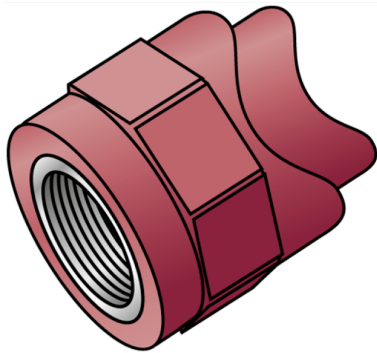

KETRIX polyfusion weld fitting for connecting POB pipes with fittings made of the same material without narrowing the cross-section, injected female thread made of dezincification-resistant brass and non-porous metal-plating, thread conforms to DIN EN 10226. For welding directly to pipelines that have already been installed; the welding is carried out with a WZ124 saddle welding tool  
Do NOT connect to threaded pipes or to cast iron fittings!

# Specifications

Product information	
VPE1	5,00 SA1
VPE2	60,00 KT1
VPE3	240,00 KT2
VPE4	5760,00 PAL
weight	0,065 KGM
text	KETRIX saddle fitting with female thread
INTRNR	39174000
main material group	KETRIX
material group	KETRIX metal fittings
code	TRI43



Art. No

label

55213H04

40-50x3/4"